

- Table of Contents -

- 1. **Guideline for product recycling**
- 2. **Product design, warnings and cautions for using the product**
 - 2-1. **Handling the printer**
 - 2-2. **Casing design**
 - 2-3. **Paper to be used**
 - 2-4. **Cleaning**
 - 2-5. **Maintenance**
 - 2-6. **Storing**
 - 2-7. **Others**
 - 2-8. **The figures of the platen retainer and the paper insertion area**
- 3. **Specifications**
 - 3-1. **Application**
 - 3-2. **Overview**
 - 3-3. **Structure**
 - 3-4. **Standard specifications**
 - 3-5. **Outer dimensions and installing position**
 - 3-6. **Connector (flexible) specifications**
 - 3-7. **Thermal head specifications**
 - 3-8. **Stepping motor specifications**
 - 3-9. **Sensor specifications**
- 4. **Product model plate**
- 5. **Packing**
- 6. **Pre-printing specifications**
- 7. **Revision history table**

A

B

C

D

A

B

C

D

E

F

Dept. to control the original document	↑
Date	

					Name	FTP-638MCL101 SPECIFICATION	
					Drawing No.	A1NA02266 - 0101/6	Submit to
Rev	Date	Design	Inspection	Changes made		FUJITSU Takamizawa Component Co., Ltd.	Page
Design			Inspect.		Approv.		2 / 2

1. Guideline for product recycling

- Fujitsu Takamizawa Component Co., Ltd. is making an effort to promote the environmental management per ISO 14001 with a policy **“Better corporate activities while valuing the environment”**
- The below lists the components and their materials used in this printer. Refer this list when the printer is to be recycled.

[FTP-638MCL101](#) List of materials

No.	Name of components	Material
1	Printer frame (gear side)	Zinc alloy
2	Printer frame (center)	Zinc alloy
3	Printer frame (switch side)	Zinc alloy
4	Gear cover	POM resin
5	Rubber roller	Silicone rubber + SUS
6	Platen gear, middle gears 1, 2 and 3	POM resin
7	Pulse motor	SPCC + iron + copper wire
8	Paper guide	PC resin
9	Switch fixture	SUS
10	Thermal head	Aluminum + ceramic substrate
11	Head pressuring spring	SUS
12	Bearing	Sintered alloy
13	FPC	PI, copper leaf, solder plating

“Abbreviations for the materials used”

- SUS: Stainless steel
- POM: Polyacetal resin
- PC: Polycarbonate
- SPCC: Rolled steel plate
- PI: Polyimide

Dept. to control the original document



Date

					Name	FTP-638MCL101 SPECIFICATION	
					Drawing No.	A1NA02266 - 0101/6	Submit to
Rev	Date	Design	Inspection	Changes made		FUJITSU Takamizawa Component Co., Ltd.	
Design			Inspect.		Approv.	Page	3 / 3

2.Product design, warnings and cautions for using the product

2-1. Handling the printer

- (1) When handling this printer, be sure to take any preventive measure against static electricity such as **Disposable Wrist Strap** in order to prevent damages of inner parts of the printer caused by the static electricity.
- (2) When attaching the platen part to the platen retainer, pay attention not to flaw or damage or smear the rubber part of the platen, the platen gear, and the bearing part (particularly, do not attach any oil or grease and foreign material on the rubber part).
- (3) Never attempt to touch the thermal head surface with bare hands. Attaching any oil or grease such as oils from palms on the heating element part may be shorten the lifetime of the thermal head. In case that any oil and grease or foreign materials are attached on it, perform the cleaning immediately. (Section 2-4 describes the cleaning.) In addition, pay attention not to hit it with something hard such as a driver.
- (4) When attaching the platen to the platen retainer of the casing, make sure that the attaching orientation of the right and left is correct.
- ~~(5) This printer is shipped as a set of the main body and the platen part; therefore, be sure to use as this set. Using the platen part with any different printer main body can not guarantee about the printing quality.~~
- (6) The thermal head and FPC are shipped as they are connected. When installing the printer, do not pull or apply any extra force in order to avoid the connected part of the thermal head and FPC from being disconnected or deviated. Using the printer with the part is deviated may destroy the head. If it is deviated or disconnected, contact us. In addition, for the connection of FPC and the control circuit side, as shown in the figure below, the checking mark for attachment is seen on FPC; therefore, follow the mark and make sure not to deviate when attaching.

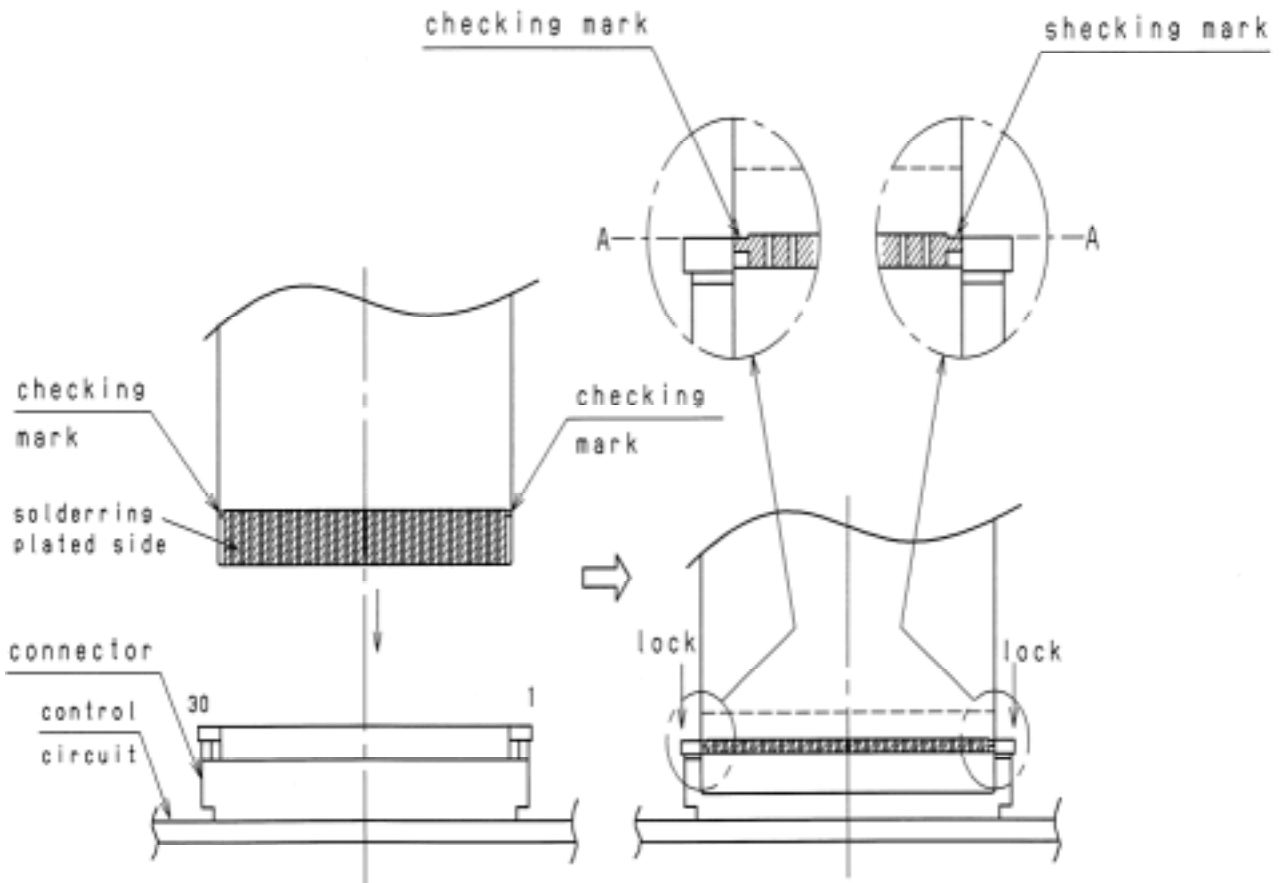

Dept. to control the original document

Date

					Name	FTP-638MCL101 SPECIFICATION	
					Drawing No.	A1NA02266 - 0101/6	Submit to
04	(5) Deletion						
Rev	Date	Design	Inspection	Changes made		FUJITSU Takamizawa Component Co., Ltd.	Page
Design			Inspect.		Approv.		4 / 4

- 1 | 2 | 3 | 4
- (7) Never attempt to touch FPC and the probe part of the signal line of FFC (parts which are soldering-plated) and not to hit them with something hard.
- (8) Do not perform the **contact bending** of FPC because it may cause the disconnection. If FPC requires to be bent, the bending should be more than R1. Once it is bent, do not rework (straighten or bend backward).

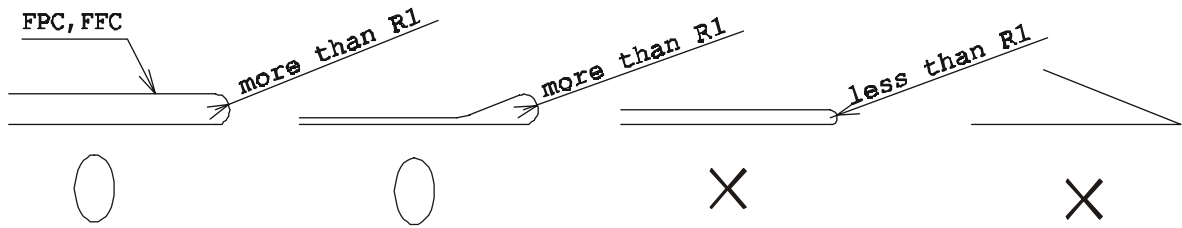

- (9) This printer has a structure such that the platen part is removed from the printer cabinet; therefore, applying the load on the platen part allows removal of the part from the cabinet. Therefore, if any paper ejected from this printer is pulled away with an unnecessarily strong force, it may cause the platen gear to get off the track and damage the gear. Do not attempt to pull any paper ejected from the printer. In addition, when stopping the paper feeding with the hand cutter attached on the main body side, take extra care not to let the gear get off the track. Furthermore, installing any licking system on the casing side of the main body side is recommended (refer to the lock mechanism on the next page).
- (10) If any voltage is applied to the thermal head when the head or paper is wet due to condensation, it may be damaged by electrolytic corrosion; therefore, when using the printer, pay attention to the following items.
- * Do not apply any electric power to the printer when it is not used.
 - * Do not perform the printing with any wet paper.
 - * Do not apply any electric power to the printer under any environment where any dew condensation is possible to occur.
 - * Turn off all electric power to the head immediately when condensation occurs. Use the head only after the head is completely dried.
 - * Depending on the environment where the printer is used (the low temperature or high humidity), condensation may be caused by water vapor generated from the used paper when performing the printing of the high printing rate (solid fills, zigzag printing); therefore, the environment should be considerably evaluated.
- (11) When any paper is not set at the printer, be sure to separate the head and the platen. If the paper is run out during the printing, stop all actions of the printer in order to prevent the printing without the paper fed. If the printing is continued without any paper fed, it may cause the trouble of the printer.
- (12) When using this printer for the continuous actions, the temperature of the head printer board (the detected temperature with the thermistor) should be equal or less than 65 degrees Centigrade for the temperature protection of IC inside of the printer as well as the surface temperature of the motor should be equal or less than 90 degrees Centigrade for the temperature protection of the motor coil.
- (13) Never attempt to any back feeding action of the paper.

Dept. to control the original document

Date

					Name	FTP-638MCL101 SPECIFICATION	
					Drawing No.	A1NA02266-0101/6	Submit to
Rev	Date	Design	Inspection	Changes made		FUJITSU Takamizawa Component Co., Ltd.	
Design			Inspect.		Approv.	Page	5 / 5

2-2 Casing design

Platen retainer

- (1) Refer to Attached Paper, Section 2-8 "The figures of the platen retainer and the paper insertion area" for attachment of the platen part. If it is used with any different size from the recommended ones, it may cause uneven printing, unfavorable removal of the platen, and troubles such as damages due to the lack of the strength; therefore, be sure to conform with the recommendation. The recommended dimension of the retainer is in a range where the angle is $11^{\circ} \pm 0.5^{\circ}$ and the size of the X-direction is 50-55mm.
- (2) Cover the platen gear part so that it is not exposed. The platen has some play against the retainer part; therefore, the gap between the platen gear and the cover should have sufficiently play.
- (3) Materials of the platen retainer should have high strength and high impact-resistance as the ones for the platen retainer (equivalent to PC or PC+ABS).
- (4) Avoid removing the platen from the platen retainer as much as possible after having attached it to the platen retainer.

Positions of the cover and the fulcrum

- (1) Refer to the figure in Section 2-8 for the fulcrum position of the cover. Make sure to set so that the position is surely above more than 10° from the centerline of the platen (the recommended angle value is $11^{\circ} \pm 0.5^{\circ}$). In addition, the recommendation value of the X-direction dimension should be within a range of 50-55mm. If the printer is used with different values from the recommended angle and X-direction dimension, contact us in advance.
- (2) The fulcrum of the cover should be parallel to the platen of this printer as much as possible (make sure to set the position of the fulcrum so that the standard line of this printer S is the reference when setting the dimension).
- (3) When having set the platen in the printer, pay attention if any load is applied to the platen part due to effects of the twisted cover or deviation of the dimensions. If any load is applied to the platen part, it will give unfavorable effects to the printing quality, the paper feeding property, and the lifetime. Confirm that the bearing does not float from the bearing part of the printer cabinet when the platen part is closed.
- (4) Materials of the cover should have high strength, high durability, and high torsional strength as the ones for the cover (equivalent to PC or PC+ABS).
- (5) To improve the detachability of the platen, attach guides for preventing the strike slip on the both sides of the cover as well as the shape of the cover should be torsional-resistant. When removing the platen, carefully check that any platen gear is lacked or deformed because the platen gear contacts to the printer. Damages to the platen gear will give unfavorable effects to the printing quality and the paper feeding property.
- (6) The paper feeding motor (a pulse motor) of the printer and the thermal head may have the hot temperature, depending on the running time. When designing the casing, consider the heat radiation property. Be sure to design the casing so that no one is allowed to directly touch with bear hands such as adopting a cover structure, etc.

Lock mechanism of the casing

The platen retainer part of this printer provides an easy retaining (locking) mechanism (the printer as a single unit can perform the printing action), which comprises of the pressure of the head and the shape of the bearing part of the sideboard. However, if the following items are considered, the lock mechanism is recommended to mount on the casing side.

- (1) When using with a portable terminal, the casing may be opened and the rolled paper inside may jump out when it is dropped or moved (particularly, while it is being carried).
- (2) Depending on the attaching orientation of the printer, loads of the cover or the rolled paper may work to directions to which the platen is removed. Due to that, the platen gear may get off the track or the platen may be detached during the printing.
- (3) When cutting the paper ejected from the printer with a manual cutter or depending on the pulling direction of the paper, the platen gear may get off the track or the platen may be detached (when locking, minimize the play of the platen as much as possible).

Dept. to control the original document

Date

				Name		FTP-638MCL101 SPECIFICATION	
				Drawing No.		A1NA02266-0101/6	
						Submit to	
Rev	Date	Design	Inspection	Changes made			
				FUJITSU Takamizawa Component Co., Ltd.			
Design		Inspect.		Approv.		Page	6 / 6

Installing the printer

- (1) When installing the printer, fix the edge part with a hook at one place and fix the rear part with screws of M2 at two places. Flatness of the installing surface of the printer should be within equal or less than 0.1mm. It is recommended that the printer is connected to the main body FG with screws of M2 at two places (refer to the figure of the installation dimension). Pay attention not to apply any extra force to the printer main body and FPC since any of such force will give unfavorable effects to the printing quality, paper traveling property (meandering, running short of the paper, and the paper jam), and life time.
- (2) When installing the printer, install it so that the printer and the rolled paper should be parallel as much as possible. When designing the casing, it should be designed so that the printer and the holder part of the roller paper are located at the place shown in the section 2-8-(6). The roller paper should be ejected smoothly so that the paper does not hit anything such as the cover. If the above is not conformed, troubles such as meandering of the printing paper, the running short of the paper, and the paper jam may occur.
- (3) The paper detection sensor is provided on the main body side of the printer; therefore, be sure to design the paper holder so that the printing paper surely contact to the sensor (refer to Section 2-8). If the printing paper floats on the sensor equal or greater than 0.7mm, the sensor may determines the paper is not fed; therefore, attach paper holding guides on the casing side for preventing the paper from floating. In addition, when the roller paper is close to the end and the last part of it comes to the paper opening paper of the printer, the paper jam may occur at the opening. This paper holding guide works as the preventive measure of this paper jam; therefore, adding this guide to the casing is recommended
- (4) When plugging in and out FPC to the connector of the control side, be sure that all power is turned off before doing that.
- (5) Use our recommended connector as the one of the control side of FPC. If any other connector is used, fully confirm the properties (the contact resistance, drawing strength, and the allowable power supply voltage) before using.
- (6) The back tension of the rolled paper should be equal or less than 0.49N (50g) including the start up. If it exceeds equal or greater than 0.49N, the platen gear may get off the track and causes to damage the gear.

Insertion direction of a rolled paper

- (1) The roller paper should be inserted under the paper guide and at the direction parallel to the guide as well as the paper should contact to the guide.
(Refer to Fig. (4) in Section 2-8. The paper feeding load (including the back tension) should be equal or less than 0.49N. If the load exceeds equal or greater than 0.49N, the platen gear may get off the track.

Closing method and the shape of the casing

- (1) Push the central part of the casing to close the platen. To do so, design the casing so that the central part can be pushed.

Others

- (1) This printer does not provide the dust-tight and drip-proof structure. Take measures for the dust-tightness and drip-proof from the main body casing side, as required.
- (2) Surfaces and edge surfaces of metallic parts may change colors; therefore, take measures for discoloration as required, such as covering with a casing.
- (3) Smoke may be generated from parts of the printer; therefore, take measures for preventing any foreign conductive materials from entering the inside as required, such as covering with a casing.

Dept. to control the original document

Date

					Name	FTP-638MCL101 SPECIFICATION	
					Drawing No.	A1NA02266-0101/6	Submit to
Rev	Date	Design	Inspection	Changes made		FUJITSU Takamizawa Component Co., Ltd.	Page
Design			Inspect.		Approv.		7 / 7

2-3 Paper to be used

- (1) Regarding the printing quality and lifetime; therefore, carefully confirm the property of the paper before using.
- (2) When using the perforated paper, the punching direction of the perforations should be set to face the thermosensitive side. The height of burrs of the perforations and dusts of them may cause troubles such as deterioration of the printing quality, the paper end sensor, the platen gear's getting off the track, and the lifetime; therefore, carefully check the perforated paper before using.
- (3) To reduce the loads during the paper feeding and to improve the sensitivity of the paper end sensor, when rolling the paper, the thermosensitive side of the paper should be faced outside.
- (4) Use the rolled paper of which inner diameter should be equal or greater than ϕ 8 (the diameter when there is not core).

2-4 Cleaning

Adhesion of dusts of the paper and foreign materials may deteriorate the lifetime of the head and platen. When they adhere, clean the head according to the following procedures.

- (1) Take measures against the static electricity such as Disposable Wrist Strap for the work.
- (2) Cleaning should be done with the cover opened and the platen part separated from the head.
 Note) Do not hit the head surface with anything hard.
- (3) Wipe off the heating element part of the head surface lightly with cotton swabs which Athyl-alcohol is applied. After Athyl-alcohol has completely been dried, set the platen and perform the action check.
 Note) Do not use anything that may destroy the heating element, such as sandpaper. Do not add any unnecessary force to the thermal head.

2-5 Maintenance

~~(1) The printer main body and the platen part are regarded as a set of this printer and subject to the maintenance work (when only the platen part is replaced, the printing quality can not be guaranteed).~~

- (1) I will do the platen unit for maintenance.
 TITLE : Platen unit.
 MODEL No. : NA02266-V062.
 Minimum order and packing unit : 100 pieces.

2-6 Storing

- (1) When storing the printer for the long-term (equal or longer than six months at the room temperature) store it with the platen separated from the thermal head. If the rubber part of the platen and the head have continued to directly contact for a long term, the rubber part will be deformed and may affect the quality of printing.
- (2) Do not store the printer in damp places and places with drastic temperature variations. Condensation on the printer may cause troubles such as thermal head damages and action failures.
- (3) Do not store the printer in dusty places. Using the printer with dusts adhered on it may cause troubles to the printing and actions.

2-7 Others

- (1) If any trouble occur, it shall be solved by mutual discussion based on this specification. Only the printer is subject to quality assurance.
- (2) Changes and additions that do not have compatibility of this specification shall be carried out according to the mutual discussion.
 However, because this printer is the standard model, changes can be carried out without notices within a range where compatibility exists.
- (3) This thermal printer comes with an 18-month warranty after the date of production (printer serial No.). Any failure caused by the customer side in the warranty period and after expiry of the warranty shall be serviced with charge. The maintenance service can be available in five year after the date of discontinuation of producing this printer.

Dept. to control the original document

Date

				Name		FTP-638MCL101 SPECIFICATION	
				Drawing No.		A1NA02266-0101/6	
						Submit to	
03				For platen unit maintenance			
Rev	Date	Design	Inspection	Changes made			
				FUJITSU Takamizawa Component Co., Ltd.			
Design		Inspect.		Approv.		Page	8 / 8

2-8 The figures of the platen retainer and the paper insertion area (including recommended value)

(1) The figure of the retainer dimension (direction of longer length)

A

platen gear

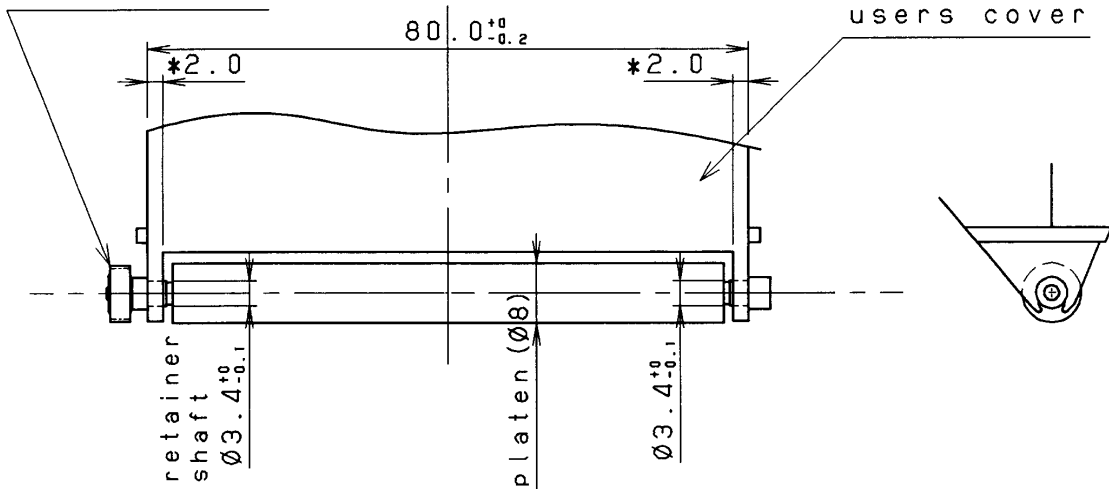

B

Notes)

1. * the dimension is a recommended one.
2. ⊙ shows the center line of the platen set in the main body of the printer.
3. Install the paper holding guide to achieve the output stabilization of the paper detection sensor.
4. You are requested to chamfer both outside of the retainer as shown in A-A cross section so that the platen can be easily mounted and demounted to the main body of the printer.

C

(2) Expansions figure of the retainer. (both sides are same shape)

note4)
A-A section

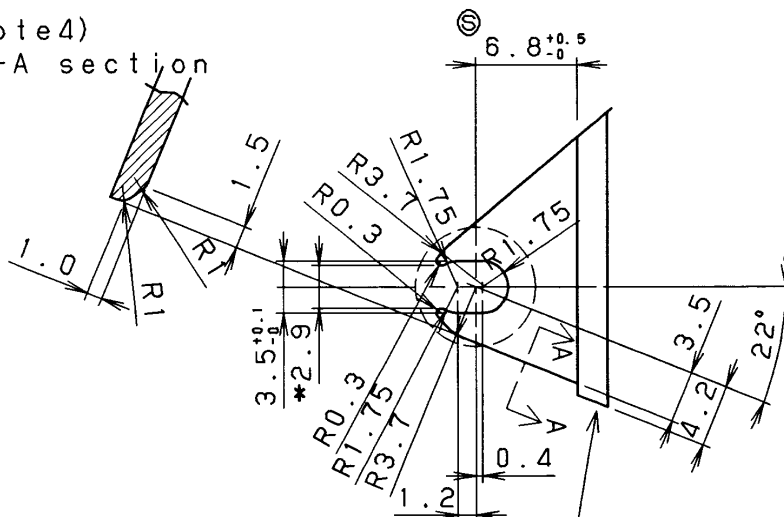

note3)
paper holding guide (more than paper width)

D

Dept. to control the original document

Date

				Name		FTP-638MCL101 SPECIFICATION	
				Drawing No.		A1NA02266-0101/6	
						Submit to	
Rev	Date	Design	Inspection	Changes made			
				FUJITSU Takamizawa Component Co., Ltd.			
Design			Inspect.		Approv.	Page	9 / 9

A

B

C

D

E

F

(3) Fulcrum position of the users cover

A

B

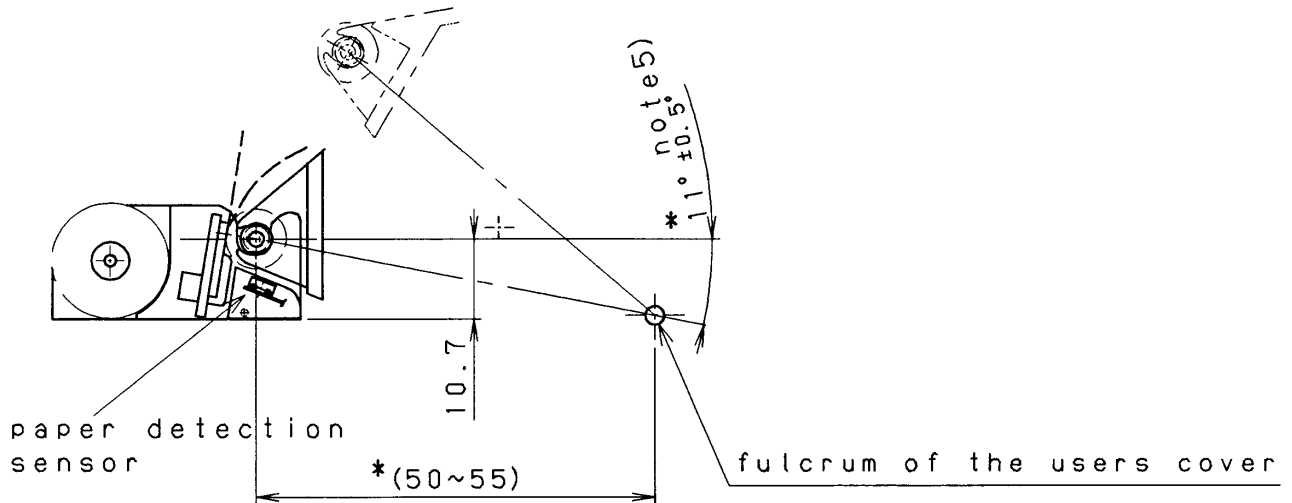

note5) Fulcrum position of the users cover is surely above more than 10° from the center line of the platen (the recommended angle value is 11° ± 0.5°)

C

(4) Insertion direction of a roll-paper

D

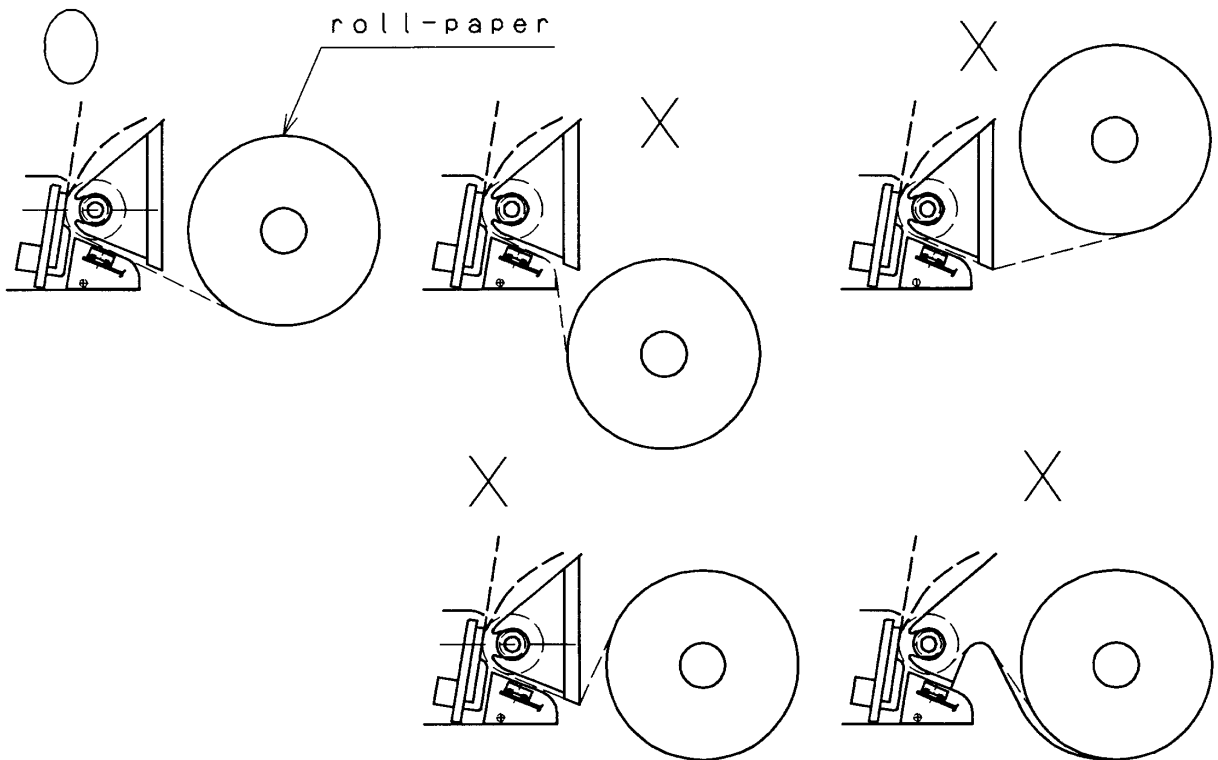

Dept. to control the original document

Date

					Name	FTP-638MCL101 SPECIFICATION	
					Drawing No.	A1NA02266-0101/6	Submit to
Rev	Date	Design	Inspection	Changes made		FUJITSU Takamizawa Component Co., Ltd.	
Design			Inspect.		Approv.	Page	10/10

(5) Details figure of the paper detection sensor

A

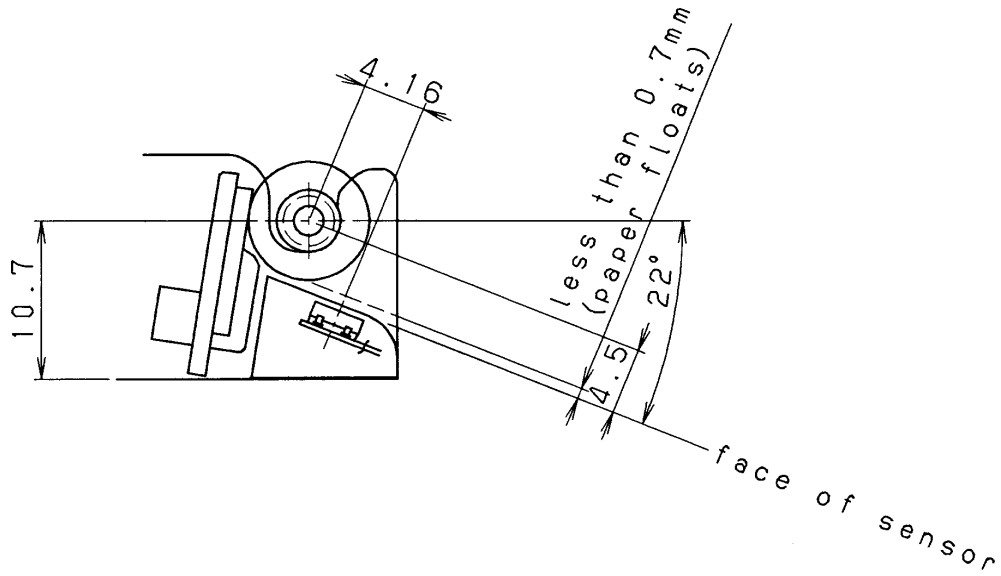

B

(6) Paper holder position

C

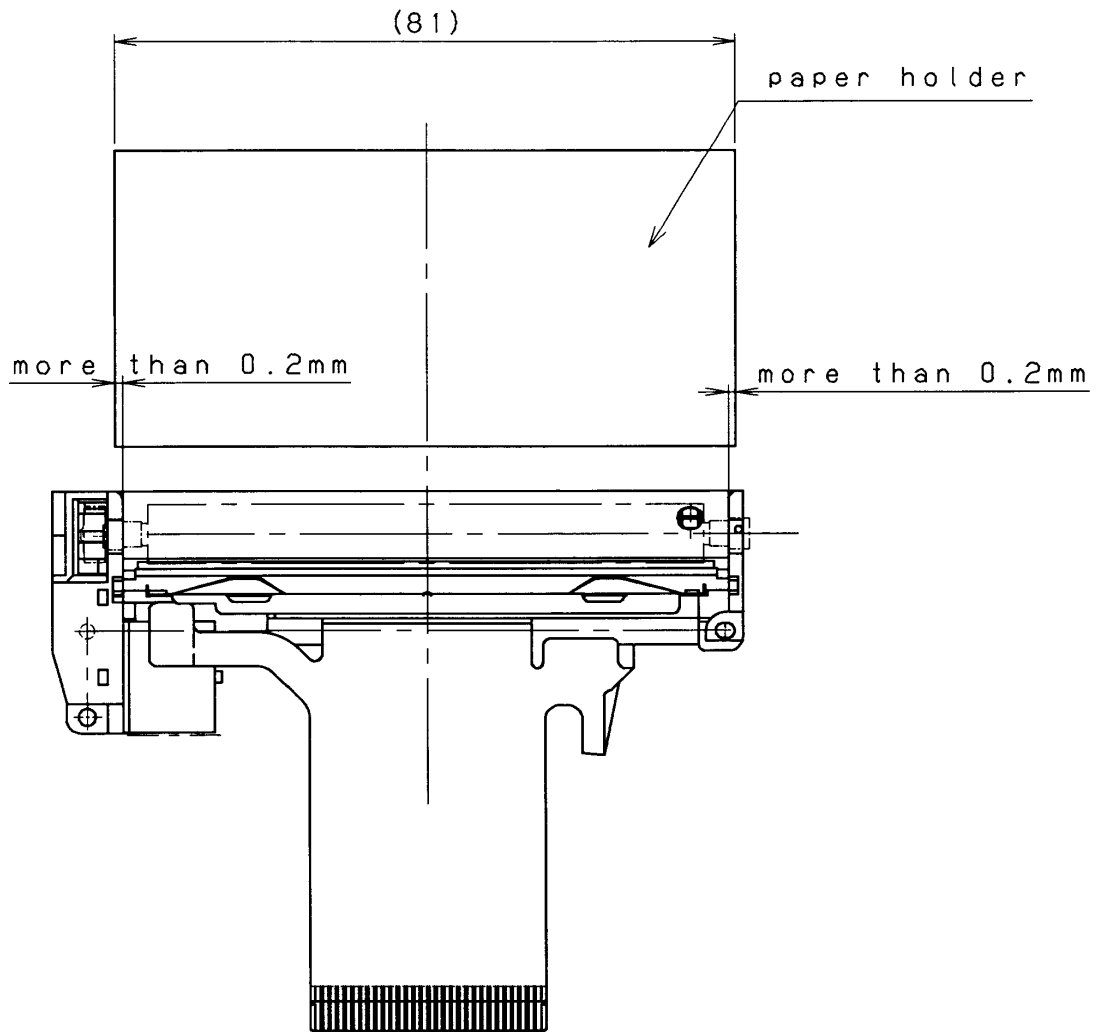

D

Dept. to control the original document

Date

					Name	FTP-638MCL101 SPECIFICATION	
					Drawing No.	A1NA02266-0101/6	Submit to
Rev	Date	Design	Inspection	Changes made		FUJITSU Takamizawa Component Co., Ltd.	
Design			Inspect.		Approv.	Page	11 / 11

3. Specifications

3-1 Application

This specification is applies to FTP-638MCL101.

Standards by this specification are satisfied by standard interface boards described below or LSI for driving and reference circuits.

- (1) Standard interface board: FTP-628DCL201
- (2) LSI for driving: FTP-628CU 201

3-2 Overview

This printer is the small and lightweight printer which build in a line dot thermal head of resolution 8 dots /mm.

To actualize easy insertion of paper, the platen part separates from the printer main body with one action.

3-3 Structure

Below is the figure of this printer's structure (the mechanical part).

Flexible hoses for head, sensor and motor connections.

Flexible hoses for head, sensor and motor connections.

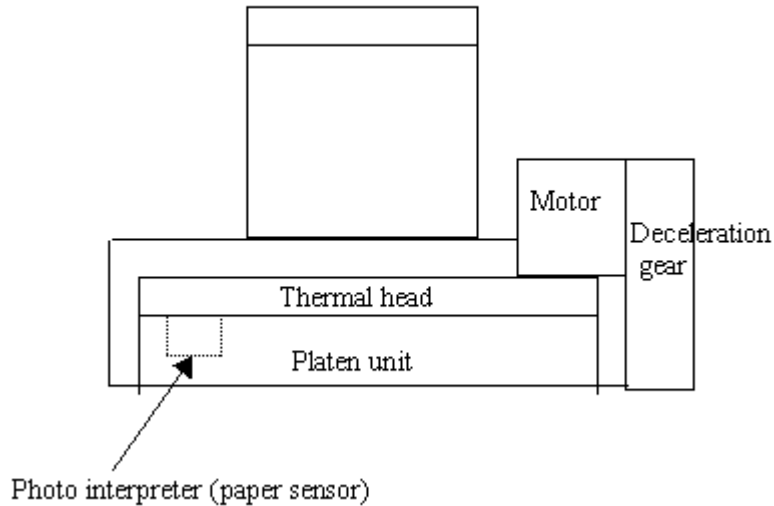

Dept. to control the original document

Date

					Name	FTP-638MCL101 SPECIFICATION	
					Drawing No.	A1NA02266-0101/6	Submit to
Rev	Date	Design	Inspection	Changes made		FUJITSU Takamizawa Component Co., Ltd.	
Design			Inspect.		Approv.	Page	12/12

3-4 Standard specifications

Item	Specifications	
A Printing specifications	Printing method	Direct thermosensitive method
	Valid printing width	72 mm
	Dot structure	576 dots /line
	Dot pitch(rsolution)	0.125 mm (8 dots/mm)
	Dot size	0.11 0.125mmx0.12mm
	Printing density	OD value greater than 0.8, in use of the specified paper under our standard printing conditions. * Measuring device: Sakura densitometer, PDA-65, by Konika Co., Ltd.
	Printing speed	50 mm/s (At 7.2 V drive) 60mm/s” At 8.5V drive, Standard paper(PD150R equivalent), Room temperature, 64 dots or less, High speed mode” At Standard paper (Paper width 58 mm)
B Specified paper for recording *1	Highly sensitive paper	TF50KS-E4 (width: 80.0 ⁺⁰ ₋₁ mm), Nippon Paper
	Standard paper	TF50KS-E (width: 80.0 ⁺⁰ ₋₁ mm), Nippon Paper
		PD150R (width: 80.0 ⁺⁰ ₋₁ mm), Oji Paper
	Middle-term preservable	TP60KS-F1 (width: 80.0 ⁺⁰ ₋₁ mm), Nippon Paper
		P220VBB-1 (width: 80.0 ⁺⁰ ₋₁ mm), Mitsubishi Paper
		PD170R (width: 80.0 ⁺⁰ ₋₁ mm), Oji Paper
	C Long-term preservable	TP50KJ-R (width: 80.0 ⁺⁰ ₋₁ mm), Nippon Paper
		AFP-235 (width: 80.0 ⁺⁰ ₋₁ mm), Mitsubishi Paper
		PD160R-N (width: 80.0 ⁺⁰ ₋₁ mm), Oji Paper
		HA220AA (width: 80.0 ⁺⁰ ₋₁ mm), Mitsubishi Paper
Paper feeding method	Friction feeding (1 dot line/4 pulses, bi-polar 1-2 phase excitation)	
Paper feeding precision	±5% At fixed-speed feed with the back tention of 0.49N or less (±2% at 25°C and RH 60%)	
Line gap in one print line by enable drive	Less than 0.125 mm, the step difference between the right and left printing lines.	
D Detective functions	Thermal head temperature detection	Thermistor
	Paper detection	Photo interrupter
	Mark detection	
External dimensions (W x D x H)	92.2±1.5mmx33±0.5mmx15.5±0.5mm(excluding FPC) Refer to the outer dimension drawing in section 3-5 for details.	
Weight	Approx 52g	
Average resistance of the thermal head	176Ω±4%	

*1: If any other paper except for the specified above is used, through the mutual discussion, the paper shall be evaluated, checked and adoption shall be determined.

Dept. to control the original document

Date

				Name	FTP-638MCL101 SPECIFICATION	
04				Drawing No.	A1NA02266-0101/6	Submit to
02						
Rev	Date	Design	Inspection	Changes made		FUJITSU Takamizawa Component Co., Ltd.
Design			Inspect.		Approv.	

Item		Specifications	
Drive power	Head	For printing Voltage: DC 4.2 V to 8.5V Current: Approx. 2.4 A (at 25°C, Rav=176Ω, 7.2V, concurrently electrified with 64 dots)	
		For logic Voltage: DC 5V±5% 2.7 to 5.25V Current: 0.2 A Max.	
	Motor drive	Voltage: DC 4.2V to 8.5V Current: 1.0 A Max. (by the F&T standard constant-current drive circuit)	
Environmental characteristics	Operating temperature and humidity *1	+5°C to 40°C, 20 to 85%RH. No dew should be allowed.	
	Temperature and humidity in storage	-20°C to 60°C, 5 to 95%RH. No dew should be allowed. Yet, the paper is not included.	
	Noise	Should not exceed 60dB at a point 1 m above from the printing mechanism position level.	
Reliability characteristics*2	Vibration (non-operation)	10 to 55 to 10Hz. Amplitude is 0.15mm. An 1 octave/min, 1G Max. 20 cycle each to X, Y, and Z directions.	
	Impact (non-operation)	50G, 11m/s, half-sine wave, 5 times each to X, Y and Z direction	
	Package drop	75 cm of 6 faces, 75 cm of corners and ridges as it is packed.	
	Temperature & humidity cycling (non-operation)	2 continuous cycles as a unit cycles: -25°C (2H) to room temp. (2H) to 65°C, 85%RH (2H) to room temp.	
Life	Head	Electric life	1 hundred-million pulses (under our standard printing conditions.)
		Wear life	Paper feed length, 50 km (printing rate 25% max.)
	Platen open life	More than 5000 times (regarding opening and closing as one time.)	
	Photo interpreter life	1.2x10 ⁴ hours (electrified time) with the recommended circuit.	
Printing start position on the left edge		4±1 mm (by paper width 79.5 mm) from the paper edge to the left printing edge. However, 1) 1PLY, when the specified paper for long-term record storage is used. 2) When no paper jam or no paper empty is present.	

*1: The guaranteed range of the printing concentration. However, its workable temperature range is 0 to +50 degrees centigrade. Refer to the figure below for the relation of the temperature and humidity.

*2: After the test, it shall satisfy the printing specification

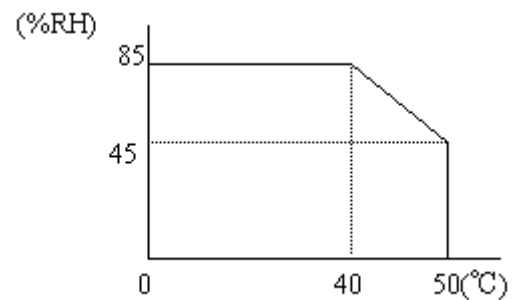

Dept. to control the original document

Date

					Name	FTP-638MCL101 SPECIFICATION	
					Drawing No.	A1NA02266-0101/6	Submit to
03	Head logic voltage Change						
Rev	Date	Design	Inspection	Changes made		FUJITSU Takamizawa Component Co., Ltd.	Page
Design			Inspect.		Approv.		14 / 14

3-5. External Dimensions and Mounting Position

(1) External dimensions

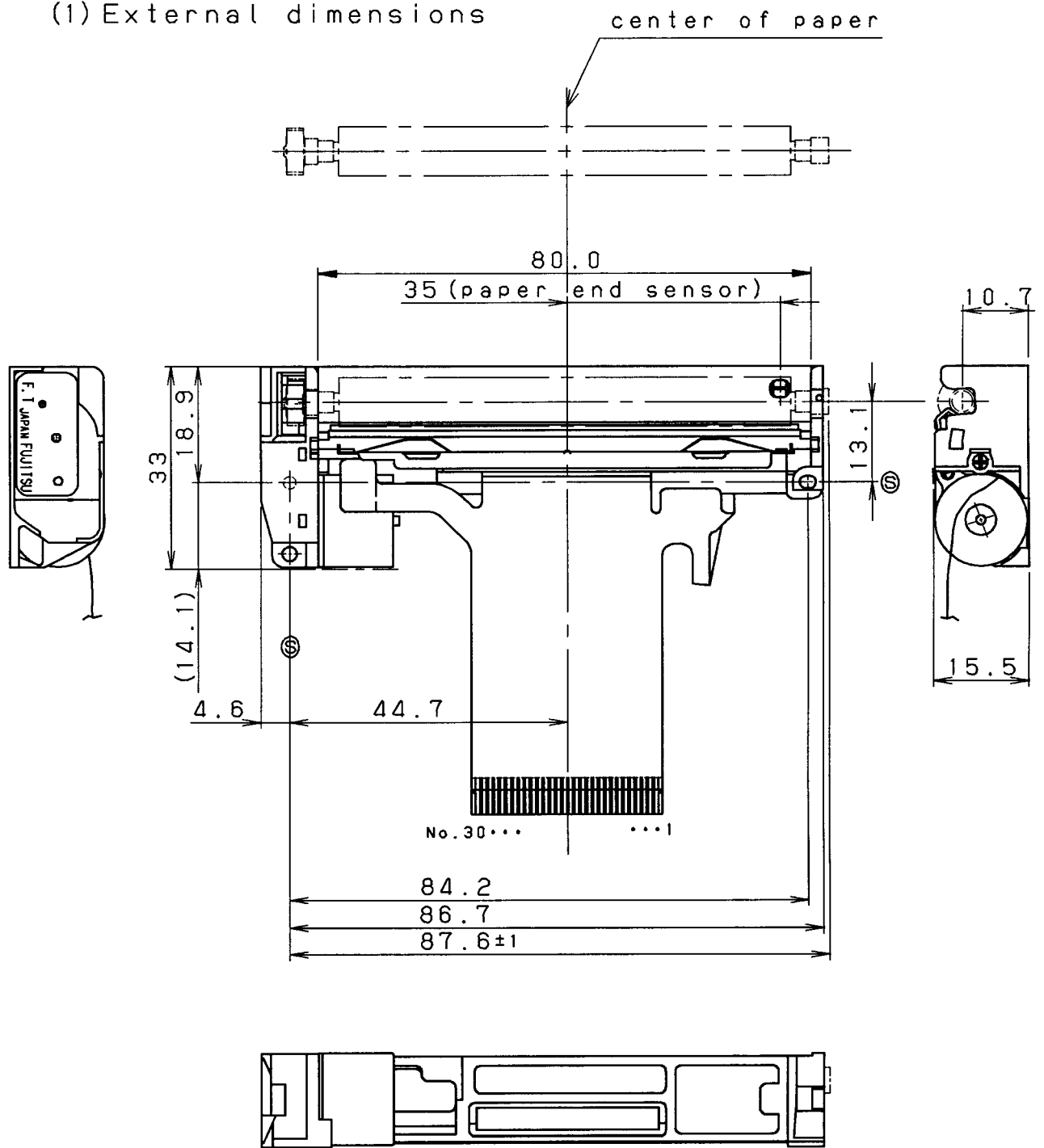

note:

1. The dimensions tolerance is $\pm 0.5\text{mm}$ unless specified.
2. Dimensions in parenthesis are eferene dimensions.
3. \oplus shows the standard center line.

Figure 1

Dept. to control the original document

Date

				Name		FTP-638MCL101 SPECIFICATION	
				Drawing No.		A1NA02266-0101/6	
						Submit to	
Rev	Date	Design	Inspection	Changes made		FUJITSU Takamizawa Component Co., Ltd.	
Design			Inspect.		Approv.	Page	15/15

(2) Mounting position

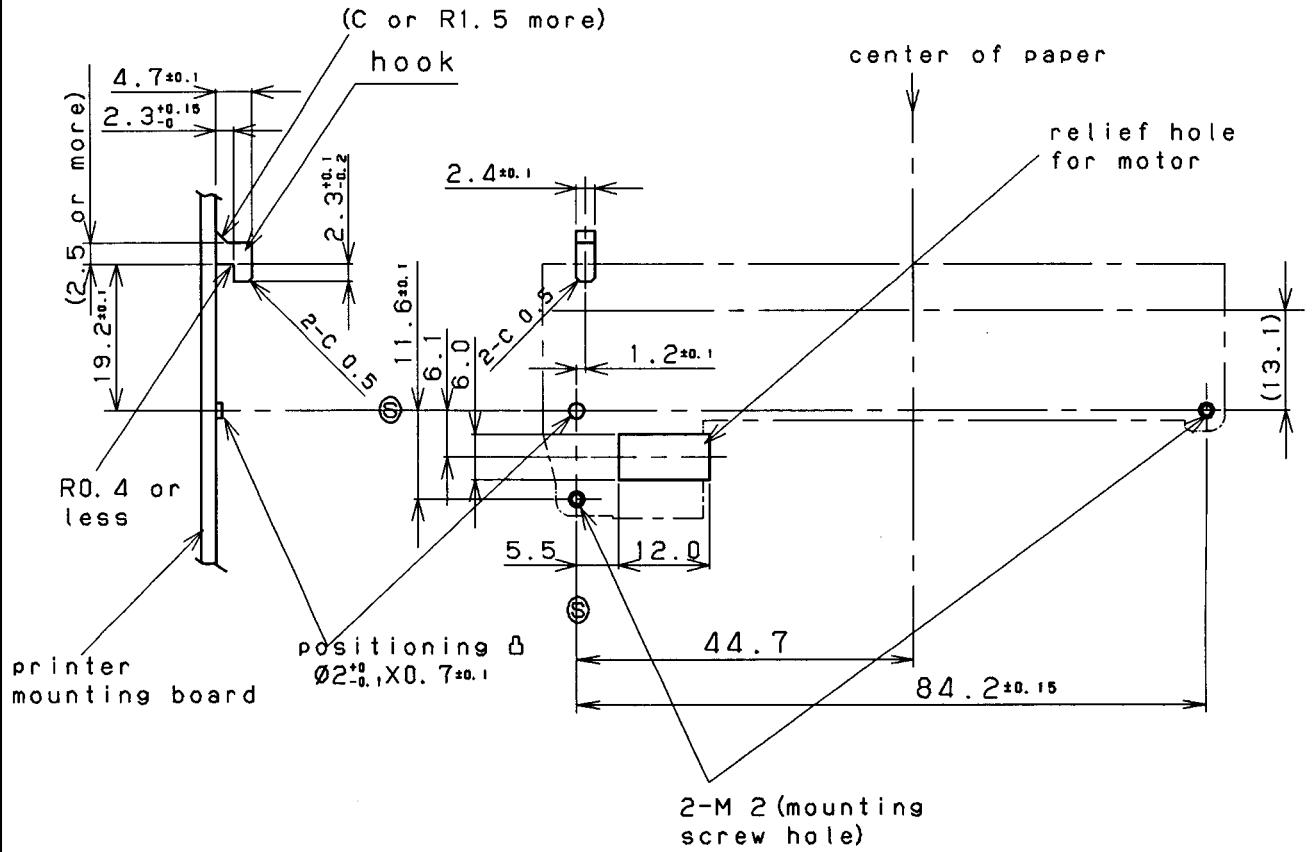

note:

- 1) The flatness of the printer mounting plate shall be within 0.1mm
- 2) mounting screw (2-M2) is contact the frame ground.

Figure 2

Dept. to control the original document

Date

				Name	FTP-638MCL101 SPECIFICATION	
				Drawing No.	A1NA02266-0101/6	Submit to
Rev	Date	Design	Inspection	Changes made		
Design			Inspect.	Approv.	FUJITSU Takamizawa Component Co., Ltd.	
					Page	16/16

3-6 Connector (flexible) specifications

- (1) Connector of the control circuit side
52030-3010 (molex)
- (2) Pin assignment (flexible) of the printer mechanical side
The pulse motor side is defined as No30.

No.	Symbol	Signal name
1	PHK	Cathode for photo interrupter
2	VSEN	Paper sensor power
3	PHE	Emitter for photo interrupter
4	N.C	Non contact
5	N.C	Non contact
6	VH	Head drive power
7	VH	Head drive power
8	DI	Data in
9	CLK	Clock
10	GND	Head ground
11	GND	Head ground
12	STB 5	Strobe 5
13	STB 4	Strobe 4
14	STB 3	Strobe 3
15	Vdd	Logic power
16	TM	Thermistor
17	STB 2	Strobe 2
18	<u>STB 1</u>	Strobe 1
19	<u>AEO 2</u>	
20	AEO 1	
21	GND	Head ground
22	<u>GND</u>	Head ground
23	LAT	Data latch
24	DO	Data out
25	VH	Head drive power
26	VH	Head drive power
27	MT / <u>A</u>	Excitation signal <u>A</u>
28	MT /A	Excitation signal A
29	MT / <u>B</u>	Excitation signal <u>B</u>
30	MT /B	Excitation signal B

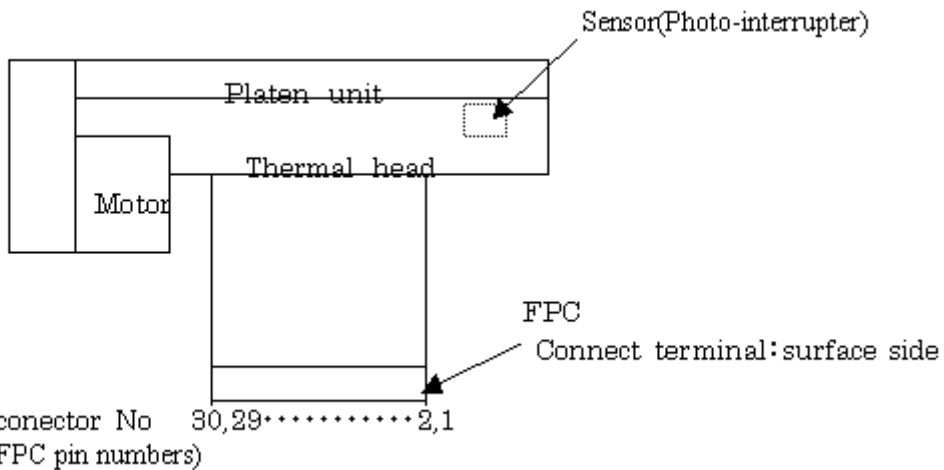

(3) Cautions

- 1) ~~Perform pull-down of five strike robe signals at about 22 kΩ.~~ Depends on (6) -5) on page 19
- 2) ~~Perform pull-down of latch signals, data input signals, and clock signals at 22 kΩ.~~

Dept. to control the original document

Date

				Name		FTP-638MCL101 SPECIFICATION	
02				Drawing No.		A1NA02266-0101/6	
						Submit to	
1 and 2 deletion (For repetition)							
Rev	Date	Design	Inspection	Changes made		FUJITSU Takamizawa Component Co., Ltd.	
Design			Inspect.		Approv.	Page	17/17

- 3) Do not plug in and out any flexible connector when the power is being supplied.
- 4) Do not add any unnecessary force to the flexible connector.
- 5) Plugging in and out FPC of the control circuit side shall be equal or less than 10 times. Do not plug in and out FPC of the head side.
- 6) GND of terminal No. 10 and 11 and GND of terminal No. 21 and 22 are separated in the head. Make them common near the flexible connector as close as possible.

3-7 Thermal head specifications

- (1) General characteristics
 - 1) System: Thermosensitive line dot system
 - 2) The total number of dots: 576 dots/line
 - 3) Heating resistor dot pitch: 0.125mm
 - 4) Heating element structure: 2 heating elements/dot
 - 5) Average resistance value of a heating element :176Ω± 4%

- (2) Maximum rating (at 25 degrees centigrade of the surrounding temperature)

Item	Max. rated value	Unit	Conditions
Printing cycle (S. L. T.)	1.25	ms/line	Tsub=25°C
Printing energy	0.5 0.2	mj/dot	
Printing power voltage: (VH)	8.5	V	Right after the battery charge. Normally, voltage is 7.2 V.
Board temperature	65	°C	Thermistor temperature.
Concurrent printing dot number	64	Dot	Note 1
Logic power voltage: (Vdd)	7	V	Including the peak voltage.
Logic input voltage: (Vin)	-0.5 to Vdd+0.5	V	

- (3) Electrical characteristics
 - 1) Electrical characteristics: Table 1
 - 2) Timing chart: Fig. 3-1
 - 3) Equivalent circuit: Fig. 3-2
 - 4) Driver structure: 64 bitsx9 drivers

- (4) Conditions for electrical actions

Item	Symbol	Electric conditions	Unit	Conditions
Power consumption	Po	0.248	W/dot	Rav=176Ω Concurrent applied dot number. With 64 dots
Supply voltage	VH	7.2	V	
Recording cycle	S.L.T	1.25	ms/line	5°C
Energy consumption (Record pulse width) (Note 2)	Eo (Ton)	0.16	mj/dot	25°C
		(0.65)	ms	
		0.13	mj/dot	45°C
		(0.54)	ms	
Current consumption	Io	2.4	A	
Division number		1		

Note 2) The printing interval (SLT) is defined as the time in which strobos are sequentially driven and the printing of one line has all been completed. The relation of the applied voltage and the electric power application time (Ton) is calculated with calculation formula as shown below.

$$Po = Io^2 \times Rav = \frac{VH^2 \times Rav}{(Rcom \times N + Rav + Ric + Rlead)^2}$$

$$Ton = Eo \div Po$$

Dept. to control the original document

Date

				Name		FTP-638MCL101 SPECIFICATION	
				Drawing No.		A1NA02266-0101/6	
02				Error in writing correction			
Rev	Date	Design	Inspection	Changes made			
Design			Inspect.	FUJITSU Takamizawa Component Co., Ltd.			
				Page	18 / 18		

or
 $Po = Eo \div Ton$
 $VH = \sqrt{(Po \div Rav) \times (Rcom \times N + Rav + Ric + Rlead)}$

Rav:	Average resistance value	(example)	176	[Ω]
N:	The number of simultaneous printing dot	(example)	64	[dot]
Rcom:	Common resistance		0.075	[Ω]
Ric:	Driver-On resistance		6	[Ω]
Rlead:	Lead resistance		10	[Ω]

(5) Thermistor characteristics

B constant: 3950K±2%
 Resistance value R25: 30KΩ±5% at25°C
 Thermistor calculation formula: $RX = R25 \times \text{EXP}\{Bx(1/TX - 1/T25)\}$ T: Absolute temperature
 Operating temp. range: -20 to +80°C
 Thermal time constant: Within 30sec (in the air)

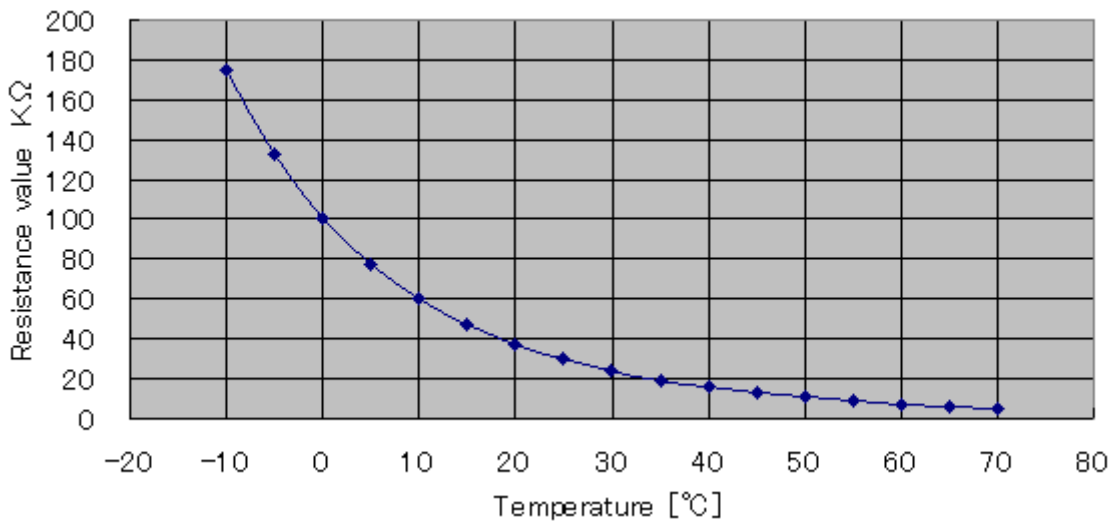

6) Cautions on operation

- 1) When performing the continuous printing with high printing rate, regulate the head base (thermistor) temperature so that it does not exceed the standard value.
- 2) For the waiting time, control (circuit design) the printer so that VH (power supply of the heating element) is turned off (the GND level) in order to prevent thermal head damages caused by ions and noises.
- 3) When the thermistor is disconnected, control (circuit design) the printer so that the thermal head is not overheated.
- 4) Do not input any pulse noise of equal or more than 2V, 20ns in each signal terminal.
- 5) Control signals of CLK, LAT, DIN, and STB with C-MOS (equivalent to 74HC240). In addition, when the power supply is on/off and for the non-printing time, maintain the STB signal in the "DISABLE" state.
- 6) **Surge noise to prevent**, the cable length of VH and GND shall be equal or shorter than 100mm. Mount an aluminum electrolytic capacitor of 47 μF between VH and GND of the head side, which should be as close to the head side as possible. In addition, mount a laminating ceramic condenser of 0.1 μF between VDD and GND.
- 7) When the power supply is on, the order shall be VDD → VH. When the power supply is off, it shall be VH → VDD.

Dept. to control the original document

Date

				Name		FTP-638MCL101 SPECIFICATION	
				Drawing No.		A1NA02266-0101/6	
						Submit to	
Rev	Date	Design	Inspection	Changes made			
				FUJITSU Takamizawa Component Co., Ltd.			
Design			Inspect.		Approv.	Page	19/19

8) Make sure not to condense dew on the head. If condensation occurs on the head, maintain the VH power supply in the off state until condensation has been solved.

Ta=25±10°C

Item	Symbol	Min.	Standard	Max.	Unit	Conditions etc.	
Printing power voltage	VH	-	-	8.5	V		
Circuit power voltage	Vdd	2.70	5.00	5.25	V		
Circuit power current	Idd	-	-	81	mA	fDI=fCLK/2	
Input voltage	H	VIH	0.8Vdd	-	Vdd	V	STB,DI,LAT,CLK
	L	VIL	0	-	0.2Vdd	V	Same as above
Data input current (DI)	H	I _{IH} DI	-	-	0.5	μA	V _{IH} =5V
	L	I _{IL} DI	-	-	-0.5	μA	V _{IL} =0V
STB input current (HIGH-ACTIVE)	H	I _{IH} STB	-	-	60	μA	
	L	I _{IL} STB	-	-	-1.0	μA	
AEO input current (LOW-ACTIVE)	H	I _{IH} STB	-	-	4.5	μA	
	L	I _{IL} STB	-	-	-150	μA	
Clock input current (CLK)	H	I _{IH} CLK	-	-	4.5	μA	
	L	I _{IL} CLK	-	-	-4.5	μA	
Latch input current (LAT)	H	I _{IH} LAT	-	-	4.5	μA	
	L	I _{IL} LAT	-	-	-4.5	μA	
Data out (DO)	H	V _{DOH}	4.45	-	-	V	OPEN status, Vdd=4.5V
	L	V _{DOL}	-	-	0.05	V	
Output voltage	VOL	-	(1.0)	-	V	Reference value, Driver output part	
Clock frequency	fCLK	-	-	8	MHz	At 3.0≤Vdd≤5.25	
		-	-	5	MHz	At 2.7≤Vdd<3.0	
Clock pulse width	tw CLK	30	-	-	ns	Refer to the timing chart.	
Data setup time	testup DI	30	-	-	ns		
Data hold time	thold DI	10	-	-	ns		
Data out delay time	td DO	-	-	120	ns	At 3.0≤Vdd≤5.25	
		-	-	150	ns	At 2.7≤Vdd<3.0	
Latch pulse width	tw LAT	100	-	-	ns		
Latch setup time	testup LAT	200	-	-	ns		
Latch hold time	thold LAT	50	-	-	ns		
STB setup time	testup STB	300	-	-	ns		
Output delay time	tdo	-	-	10	μs	At 5.0V(Vdd)	
		-	-	60	μs	At 2.7V(Vdd)	

Table-1 Electrical characteristics

Dept. to control the original document

Date

				Name		FTP-638MCL101 SPECIFICATION	
				Drawing No.		A1NA02266-0101/6	
03				≤→<(Two places)		Submit to	
Rev	Date	Design	Inspection	Changes made		FUJITSU Takamizawa Component Co., Ltd.	
Design			Inspect.		Approv.	Page	20/20

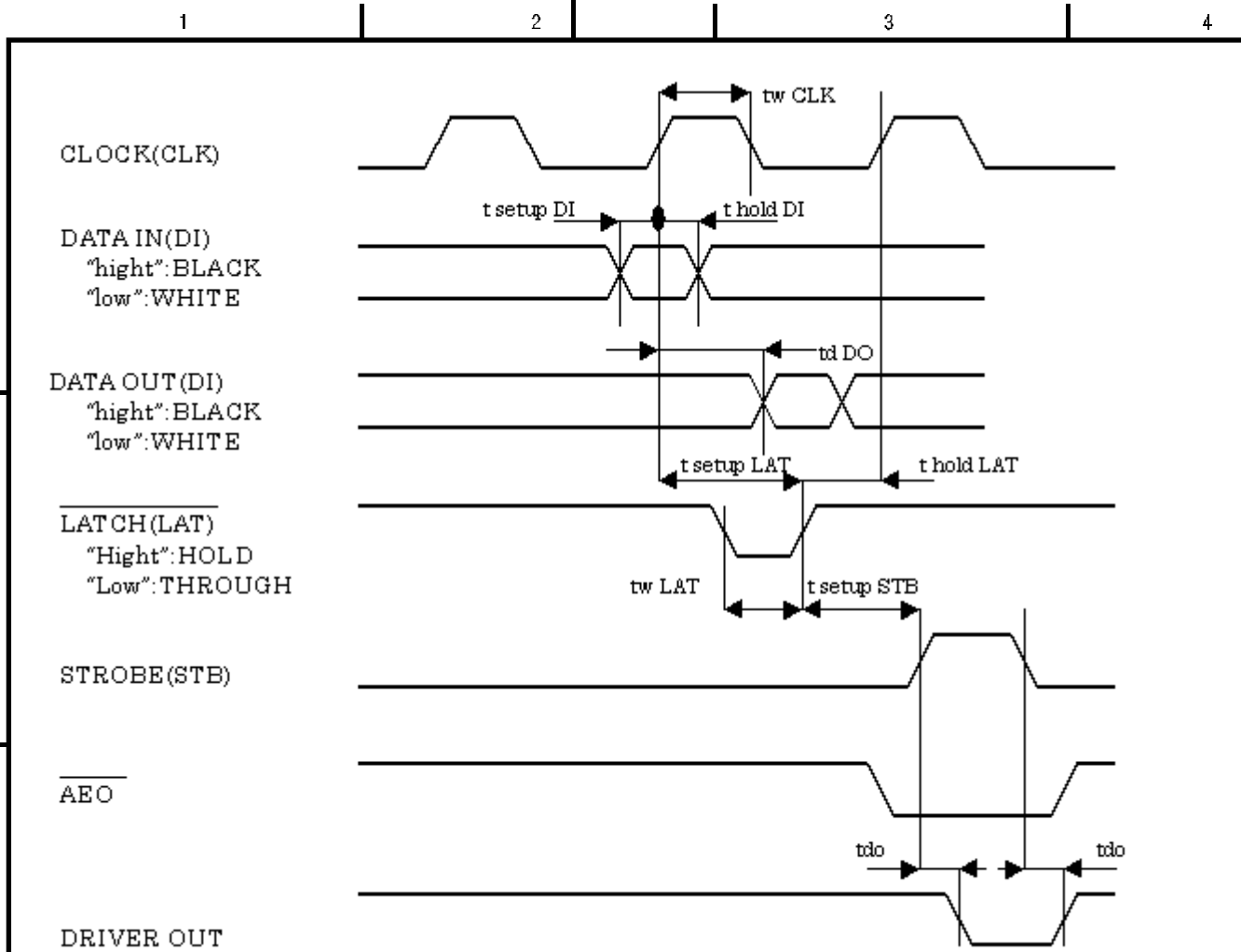

Figure3-1 Timing chart

Dept. to control the original document
 Date

					Name	FTP-638MCL101 SPECIFICATION	
					Drawing No.	A1NA02266-0101/6	Submit to
Rev	Date	Design	Inspection	Changes made		FUJITSU Takamizawa Component Co., Ltd.	
Design			Inspect.		Approv.	Page	21/21

A

B

C

D

Date

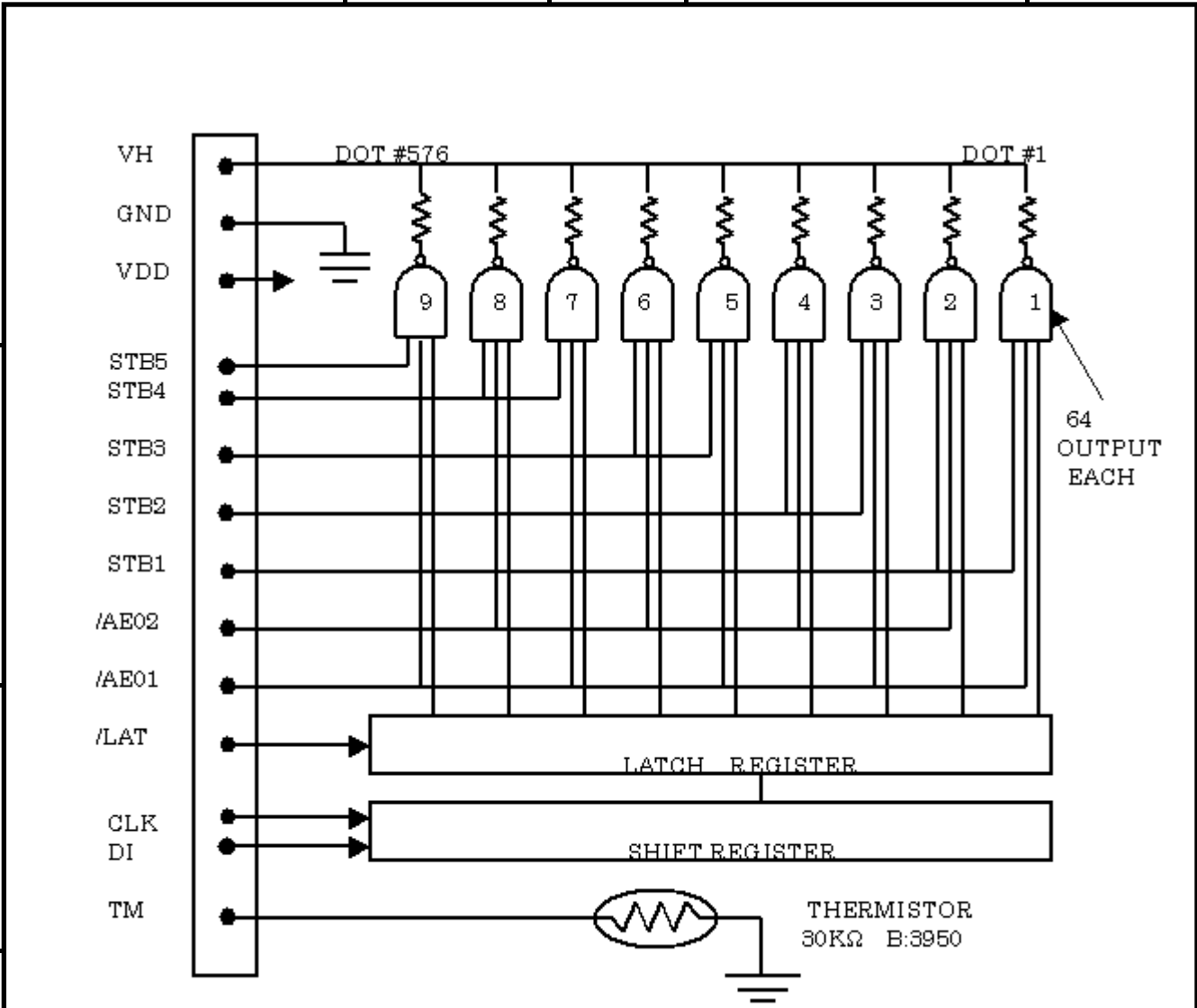

IC No.	1	2	3	4	5	6	7	8	9
STB No.	1	1	2	2	3	3	4	4	5
AE0 No.	1	2	1	2	1	2	1	2	1

Figure3-2 Equivalent circuit

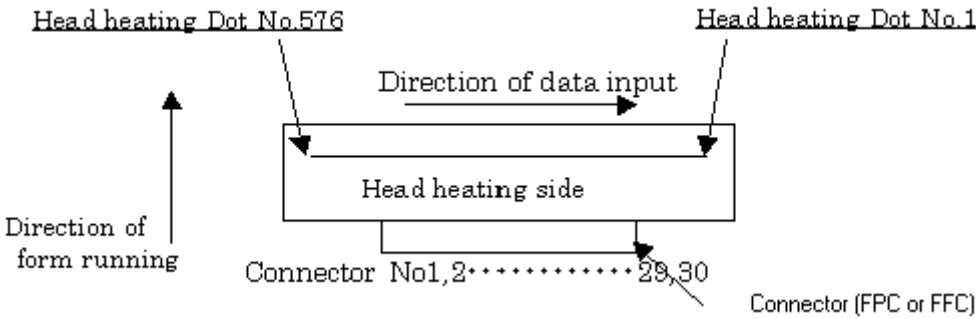

Dept. to control the original document

				Name		FTP-638MCL101 SPECIFICATION	
				Drawing No.		A1NA02266-0101/6	
				Submit to			
04	Date			Design			Dot No postscript etc.
Rev	Date	Design	Inspection	Changes made			FUJITSU Takamizawa Component Co., Ltd.
Design			Inspect.		Approv.	Page	22/22

3-8 Stepping motor specifications

(1) General specification (motor only)

Item	Specifications
Model	Permanent magnet type
Phase	Two phase (bi-polar specification)
Step angle	9 degrees by 1-2 phase excitation
Winding resistance / phase	9.6Ω±8% 9.5Ω±8%(at 25°C)
Rated voltage	DC4.2 to 8.5 V

(2) Driving procedures of the stepping motor

- 1) Drive the motor with the 1-2 phase excitation of the bipolar.
- 2) The number of steps per dot line of printing

Excitation method	Step No.	Rotation angle
1-2 phase excitation	4	9 degrees /step

3) The reference excitation method is described below.

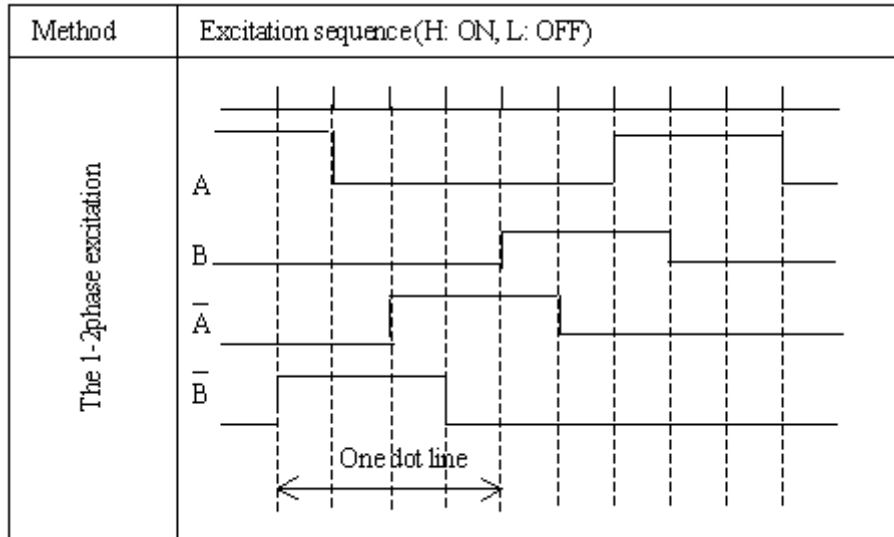

(3) Driving the bipolar transistor

- 1) Drive the motor by the fixed current control for the output torque stabilization to the applied voltage change. This reference excitation current is 440mA. Applying any excessive electric current will cause the abnormal generation and the excessive torque, which will end in mechanical damages; therefore, do not apply any electric current that exceeds the requirement.
- 2) Determine the motor driving requirements after confirming effects of load variations caused by temperature, the humidity, and types of paper. If the motor is driven by any excessive torque, the gears may be damaged when the paper is locked; therefore, attention should be paid.
- 3) In the low-speed drive (the low driving frequency), abnormal noises and the torque reduction may occur due to resonance of the motor. In the low-speed drive, be sure to perform sufficient evaluation and confirmation.
- 4) The reference exciting current when the pressurization power supply is applied is 440mA.

Dept. to control the original document

				Name		FTP-638MCL101 SPECIFICATION	
02				Drawing No.		A1NA02266-0101/6	
Error in writing correction				Submit to			
Rev	Date	Design	Inspection	Changes made		FUJITSU Takamizawa Component Co., Ltd.	
Design			Inspect.	Approv.	Page	23/23	

Applying any excessive electric current will generate the excessive torque and cause mechanical damages; therefore, do not apply any electric current that exceeds the requirement.

A

- 5) At the start of the high-speed printing and the start of the printing after turning off the motor excitation, perform the speedup control.

A

(5) Cautions

- 1) If the motor is stopped and its excitation is turned off while the printing is being performed, because of the elasticity of the rubber roller, troubles may occur at the restart of the motor: the order of the printing may be disconnected, the printing may be smudged, white lines may be inserted. When the printing contents are necessary to be continued, complete the printing without interrupting once it is started. In addition, applying the slight electric current in the waiting state can reduce effects such as deformation of the rubber roller, as shown above. In this case, the reference electric current should be 150mA.

B

- 2) When leaving the printer for the long term, turn off the excitation. Failure to do so, it may cause heat generation of the motor and the driving elements.

B

- 3) The motor side wall temperature shall be equal or less than 90 degrees centigrade. If the temperature exceeds 90 degrees centigrade, the coil inside of the motor may be damaged.

- 4) When any abnormal state occurs, stop driving the printer as soon as possible.

C

- 5) This printer performs one paper feeding operation of one dot line with four steps. Therefore, for power saving and stable actions, when driving the motor with the 1-2 phase excitation, control the motor so that it is stopped in the 1-phase excitation state and started in the 2-phase excitation.

C

- 6) Any printing action with the platen closed and no paper fed may wear the rubber roller and damage the head. Do not perform the printing in this state.

D

D

Dept. to control the original document

D

E

Date

					Name	FTP-638MCL101 SPECIFICATION			
					Drawing No.	A1NA02266-0101/6		Submit to	
Rev	Date	Design	Inspection	Changes made		FUJITSU Takamizawa Component Co., Ltd.			
Design			Inspect.		Approv.	Page	24/24		

F

3-9 Sensor specifications

3-9-1 Photo-interrupter specification

This photo-interrupter is mainly used for detecting whether the paper is set. In addition, it can be used as the paper-positioning tool by seeking the mark.

(1) Absolute maximum rating

Item		Symbol	Rated value	Unit
Input	Forward current	I_F	50	mA
	Reversed voltage	V_R	5	V
	Loss of capacity	P	70	mW
Output	Voltage between the collector and emitter	V_{CEO}	20	V
	Voltage between the emitter and collector	V_{ECO}	5	V
	Collector current	I_C	20	mA
	Loss of collector	P_C	70	mW

(2) Electric optics characteristics

(25°C)

Item	Mark	Min. value	Ref. value	Max. value	Unit	Requirement	
Input	Forward voltage	V_F	1.0	1.2	1.6	V	$I_F=10\text{mA}$
	Reverse current	I_R	--	--	10	μA	$V_R=5\text{V}$
Output	Dark current	I_{CEO}	--	--	200	nA	$V_{CE}=10\text{V}, I_F=0\text{mA}$
Transfer characteristics	Photocurrent	I_C	150	--	600	μA	$V_{CE}=5\text{V}, I_F=10\text{mA}$
	Leakage current	I_{LEAK}	--	--	1	μA	$V_{CE}=5\text{V}, I_F=10\text{mA}$
	Response time (rising)	t_r	--	5	--	μs	$V_{CE}=5\text{V}, I_F=1\text{mA}$ $R_L=100\Omega$
	Response time (dropping)	t_f	--	5	--	μs	

(3) Connecting circuit

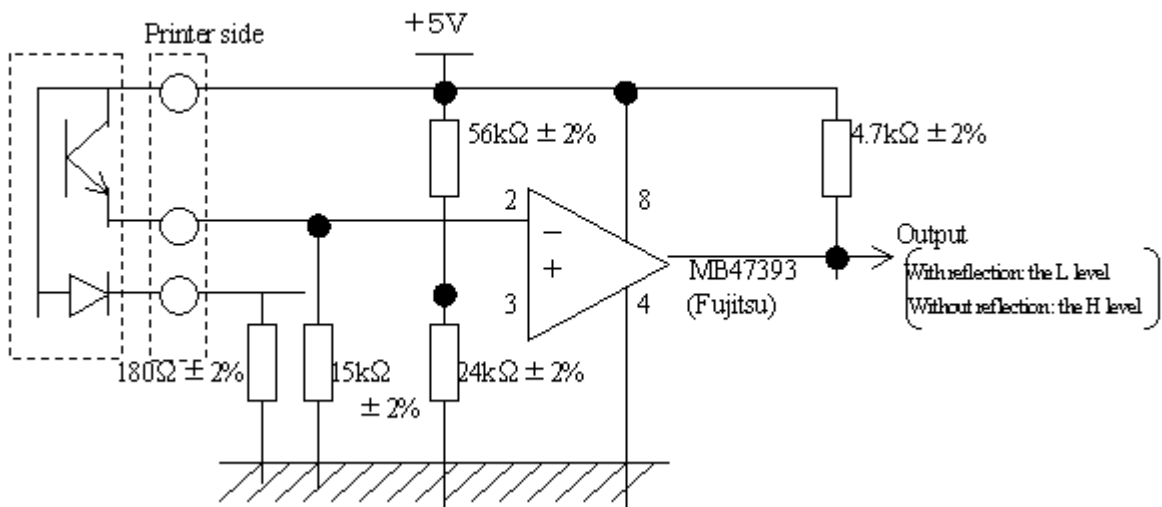

Dept. to control the original document

Date

				Name	FTP-638MCL101 SPECIFICATION	
				Drawing No.	A1NA02266-0101/6	Submit to
Rev	Date	Design	Inspection	Changes made		FUJITSU Takamizawa Component Co., Ltd.
Design			Inspect.	Approv.		Page 25/25

4. Product model plate

- (1) Contents to be indicated: The model, manufacturing additional No., and version No.
- (2) Indicating locations: Labels are plated on the gearbox side.
- (3) Indicating methods: The model, additional and version numbers are stamped.
- (4) Indication of the additional No.: The indicating method is described as follows. It is consisted of a six-digit character string.

* * * * *
* * * * *
- (5) Indication of the version No.: Manufacturing simple additional No. is indicated.
It indicates the last digit of the production month.
(X: October, Y: November, Z: December)
It indicates the last digit of the production year.
It indicates the version No. of the printer.

A

A

5. Packing

- (1) Packing state: It is individually packed in an anti-static bag and contained in an exclusive packing box.
- (2) Dimensions: They are conformed to our standard.
- (3) Number of boxes to be piled up: If it is placed horizontally, up to three boxes can be piled up in maximum.
- (4) Indication: The model and quantity is plated on the outside of the packing box.

B

B

C

C

D

D

E

Dept. to control the original document

Date

					Name	FTP-638MCL101 SPECIFICATION	
					Drawing No.	A1NA02266-0101/6	Submit to
Rev	Date	Design	Inspection	Changes made		FUJITSU Takamizawa Component Co., Ltd.	Page
Design			Inspect.		Approv.		26/26

F

6. Pre-printing specifications

6-1 Position of the detecting mark

When printing, the mark should be the width equal to or more than 5 ± 1 mm x 10mm and printed on the thermosensitive side, as shown below.

A

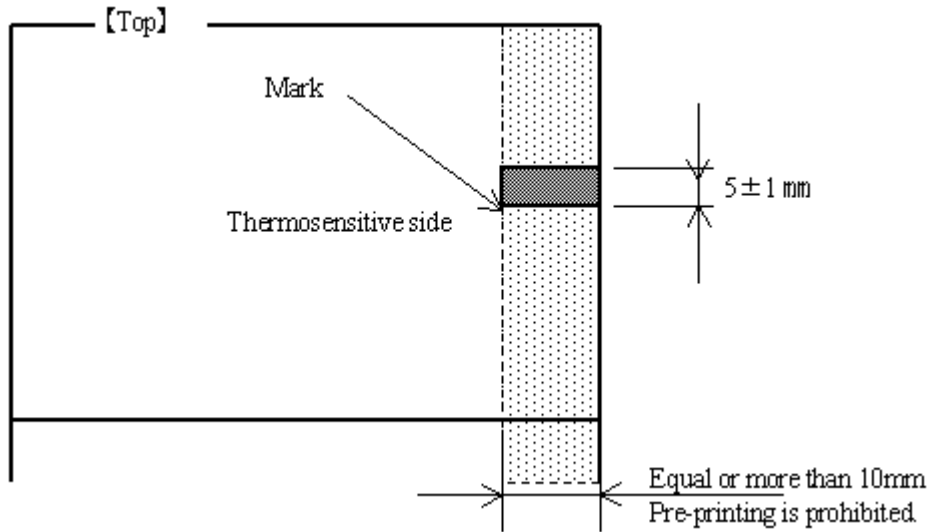

B

6-2 Pre-printing the positioning mark

The positioning mark should be printed as follows: the color is black, the reflection rate is equal or less than 7% and PCS is equal or more than 0.9 for the deepness.

To eliminate the light and shade, use the oil-base ink for printing the mark. To improve the PCS value, overprinting is recommended.

The measuring apparatus and value for deepness are described below.

- PCS measuring apparatus: GretagMacbeth reflection type densitometer PCM-II (Filter used: D-range of 900nm)

C

6-3 Prohibiting the pre-printing

Pre-printing in the range where the mark is detected (10 mm from the right edge) is prohibited; however, if pre-printing is required for absolute necessity, select the used ink so that the reflection rate is equal or more than 80% within the range where the wavelength band of the photo-interrupter is used (700-1000 nm).

6-4 Cautions on pre-printing

The thermosensitive paper has different characteristics from those of general printed paper and non-carbon paper. In the print process, pay attention to the followings.

- A Printing method
Print the thermosensitive paper by the UV print method because the drying characteristics of the ink is bad.
- B Ink to be used
 - (1) Select the ink that does not give unfavorable effects to the thermal printer, such as adhesion of work-up, wear of the head, and sticking.
 - (2) The quantity of the ions, Na and K in the ink should be respectively equal to or less than 50ppm. In addition, the quantity of ion of Cl should be equal to or less than 100ppm.

Recommended ink: RNC type by F&K TOKAI

D

Dept. to control the original document

Date

				Name		FTP-638MCL101 SPECIFICATION	
				Drawing No.		A1NA02266-0101/6	
						Submit to	
Rev	Date	Design	Inspection	Changes made			
				FUJITSU Takamizawa Component Co., Ltd.			
Design		Inspect.		Approv.		Page 27/27	

A

B

C

D

E

F

A

A

- (3) The surface strength of the thermosensitive layer is weaker than that of the general printed paper; therefore, pay attention to **tacks of the ink**. Set **the tack of the ink** to about 6.0 for the general thermosensitive paper, to the same level as the non-carbon paper for the high saving type thermosensitive paper. However, when reducing the tuck with a reducer, the quantity of addition should be equal to or less than 5%. (Failure to do so, the drying characteristics will be worse.)
- (4) Do not introduce too much quantity of the ink. Excessive amount of the ink may cause defectiveness of the printing color development and sticking of the thermal printer.
- (5) Materials used for the ink should be heat-resistant and have cooling effects. The same ink should be used for the non-thermosensitive paper side.
- (6) After the printing has been completed, confirm if the ink is contacted to the paper. Furthermore, the UV ink is generally weak to the water; therefore, care should be taken for controlling the dampening solution.
- (7) Make sure that transcription and blocking of the ink do not occur.
- (8) Do not remove the pre-printing with water or alcohol.

B

B

C Dampening solution

- (1) The thermosensitive paper is water-repellent; therefore, care should be taken for controlling the dampening solution.
- (2) Excessive amount of IPA of the dampening solution may cause color development fog; therefore, the amount should be equal to or less than 5% for the general thermosensitive paper, equal to or less than 10% for the high saving type thermosensitive paper, respectively.

C

C

D Others

- (1) When a large number of UV lamps are used, care should be taken for paper shrinkage due to heat (the flow direction, the width direction) and the color development fog.
- (2) The paper surface is quite smooth; therefore, set the rolling pressure to be strong.
- (3) When increasing in the PCS value of the positioning mark, perform the overprinting.
- (4) Sticking may occur in some pre-printing results; therefore, be sure to perform evaluation and confirmation with the actually operated unit.

D

D

Dept. to control the original document	↑
Date	

E

					Name		FTP-638MCL101 SPECIFICATION		
					Drawing No.		A1NA02266-0101/6		
							Submit to		
Rev	Date	Design	Inspection	Changes made		FUJITSU Takamizawa Component Co., Ltd.		Page	28/28
Design			Inspect.		Approv.				

F

7. Revision history table

MODEL:FTP-638MCL101

SPECIFICATION REVISION	PRODUCT REVISION	ITEM/CHANGE-CONTENTS	APPLIED-TIME	A REMARKS COLUMN
REV.0	01A			
REV.02	02A	Review and error in writing correction Platen retainer spring addition Page13:Print speed change Page17:1) and 2) deletion (For repetition) Page18, 23:Error in writing correction.		
REV.03	03A	Washer change and another Page8 :For platen unit maintenance. Page14:Head logic voltage Change Page20: ≤→< (Two places) (Error in writing correction)		
REV.04	03A	Page4: (5) Deletion Page13:Dot size change(Error in writing) Page22: Dot No postscript etc.		

A

B

C

D

A

B

C

D

E

Dept. to control the original document



Date

04																																
03																																
02																																
Rev	Date	Design	Inspection	Changes made										Name	FTP-638MCL101 SPECIFICATION																	
Design			Inspect.															Approv.														

Drawing No.

Submit to

FUJITSU Takamizawa Component Co., Ltd.

Page

29/29