













	1	2	3	4	5	6											
A	<p>MPU</p>  <p>File: D213ECX.kicad_sch</p>	<p>Power Supply</p>  <p>File: RY1303.kicad_sch</p>	<p>Memory</p>  <p>File: SD_SPI-NAND.kicad_sch</p>	<p>Debug</p>  <p>File: CH340N.kicad_sch</p>	<p>Gateway</p>  <p>File: MiniPCIE.kicad_sch</p>	<p>LVDS-MIPI</p>  <p>File: Display.kicad_sch</p>	<p>WIFI&BT</p>  <p>File: WIFI&BT.kicad_sch</p>										
B	<p>RGMII</p>  <p>File: YT8521S.kicad_sch</p>	<p>POE</p>  <p>File: TX4138.kicad_sch</p>	<p>Audio</p>  <p>File: ES8374.kicad_sch</p>	<p>USB</p>  <p>File: OTG.kicad_sch</p>	<p>MISCs</p>  <p>File: MISCS.kicad_sch</p>	<p>COMM</p>  <p>File: RS485&CAN.kicad_sch</p>											
C																	
D							<table border="1"> <tr> <td colspan="2">Sheet: /</td> </tr> <tr> <td colspan="2">File: D213ECX-GW-V1.0.kicad_sch</td> </tr> <tr> <td colspan="2">Title:</td> </tr> <tr> <td>Size: A4</td> <td>Date:</td> </tr> <tr> <td>KiCad E.D.A. kicad 7.0.7</td> <td>Rev: Id: 1/14</td> </tr> </table>	Sheet: /		File: D213ECX-GW-V1.0.kicad_sch		Title:		Size: A4	Date:	KiCad E.D.A. kicad 7.0.7	Rev: Id: 1/14
Sheet: /																	
File: D213ECX-GW-V1.0.kicad_sch																	
Title:																	
Size: A4	Date:																
KiCad E.D.A. kicad 7.0.7	Rev: Id: 1/14																
	1	2	3	4	5	6											

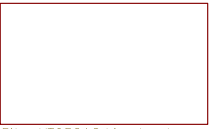

Sheet: /MPU/ File: D213ECX.kicad_sch	
Title:	
Size: A4	Date:
KiCad E.D.A. kicad 7.0.7	Rev: Id: 2/14

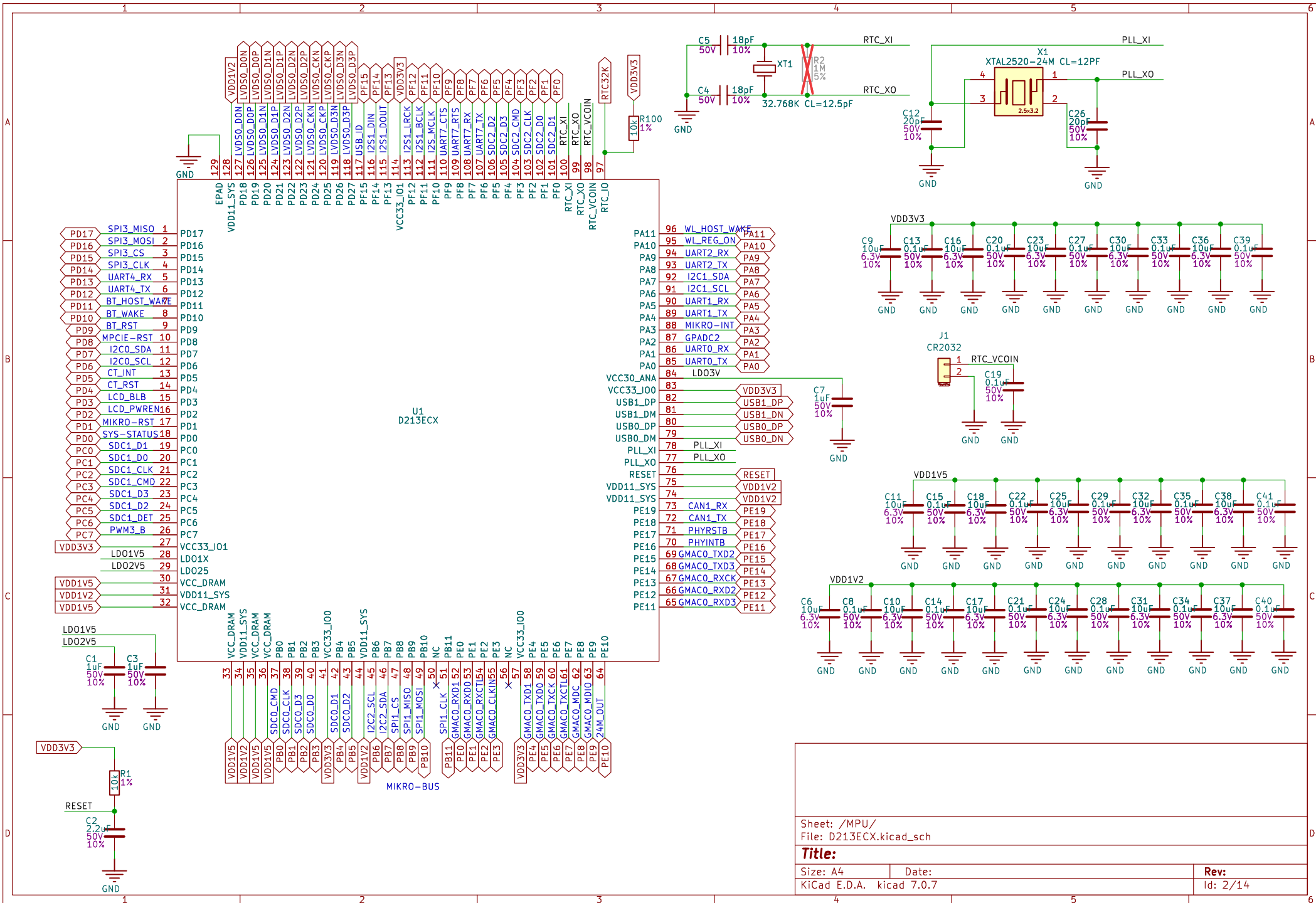
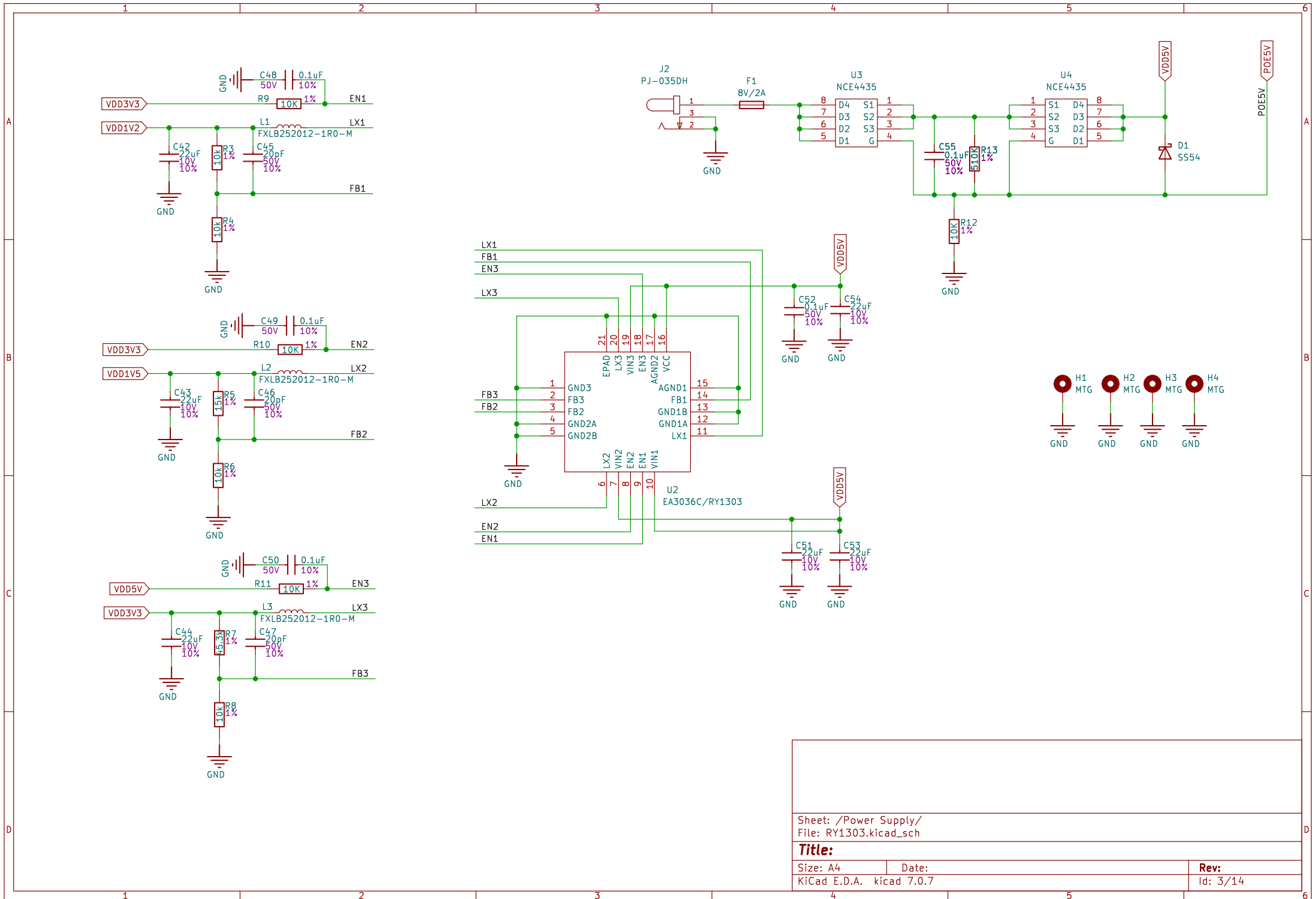

Sheet: /Power Supply/
 File: RY1303.kicad_sch

Title:

Size: A4
 KiCad E.D.A. kicad 7.0.7

Date:

Rev:

Id: 3/14

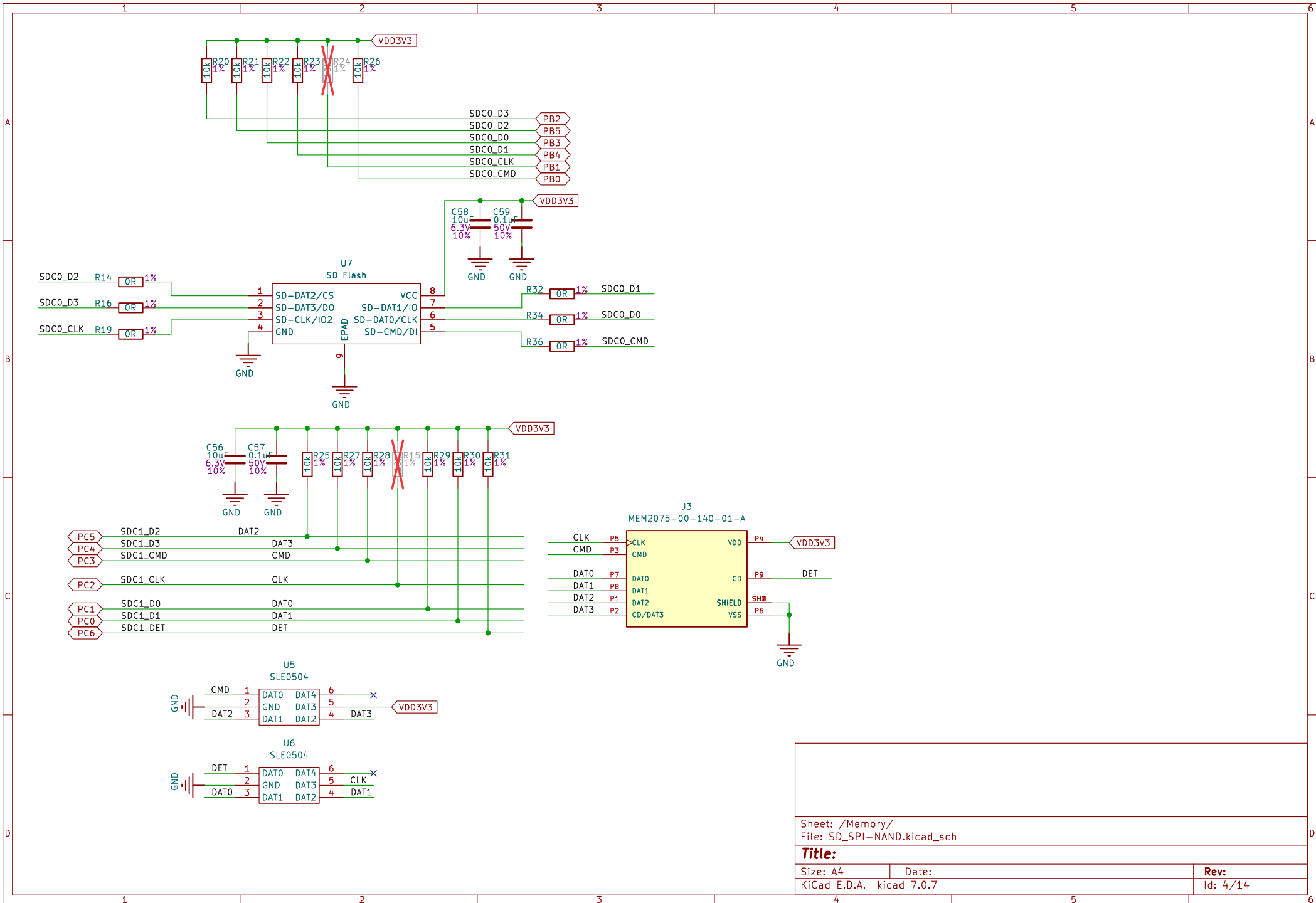

Sheet: /Memory/
 File: SD_SPI-NAND.kicad_sch

Title:	
Size: A4	Date:
KiCad E.D.A. kicad 7.0.7	Rev: 4/14

Debug

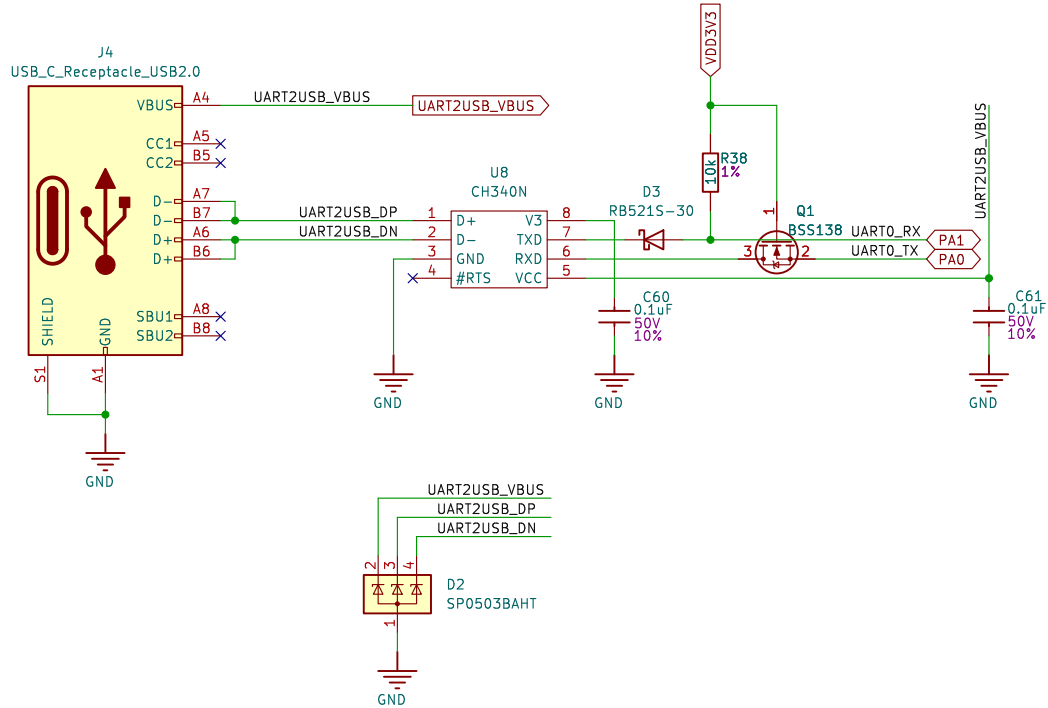

Sheet: /Debug/
File: CH340N.kicad_sch

Title:

Size: A4
KiCad E.D.A. kicad 7.0.7

Date:

Rev:
Id: 5/14

PD17	SPI3_MISO	LoRa-SPI-MISO
PD16	SPI3_MOSI	LoRa-SPI-MOSI
PD15	SPI3_CS	LoRa-SPI-CS
PD14	SPI3_CLK	LoRa-SPI-CLK
PD13	UART4_RXD	LoRa-UART-TXD
PD12	UART4_TXD	LoRa-UART-RXD

PD8 MPCIE-RST

PD7	I2C0_SDA	GNSS-SDA
PD6	I2C0_SCL	GNSS-SCL

USBH-DN	USB-MPCIE-DN
USBH-DP	USB-MPCIE-DP

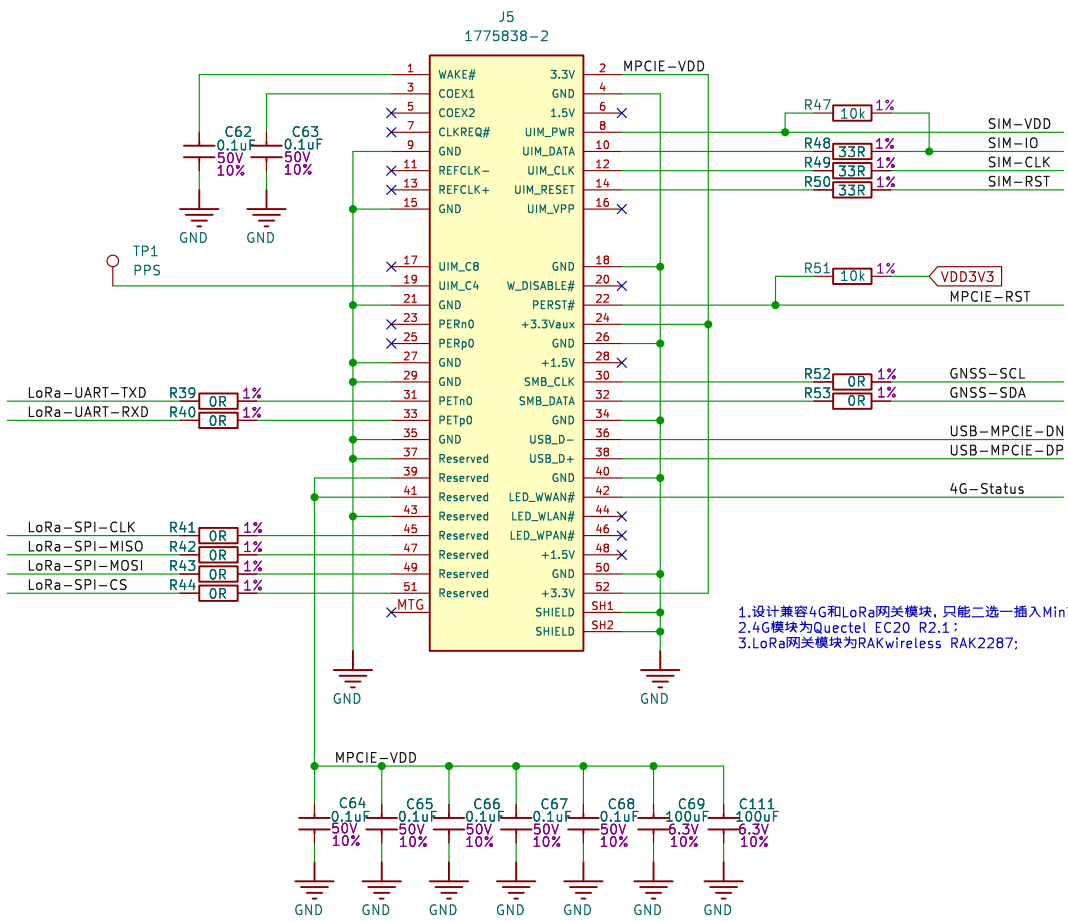
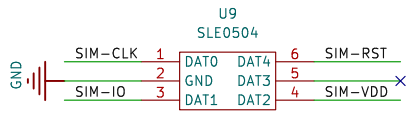
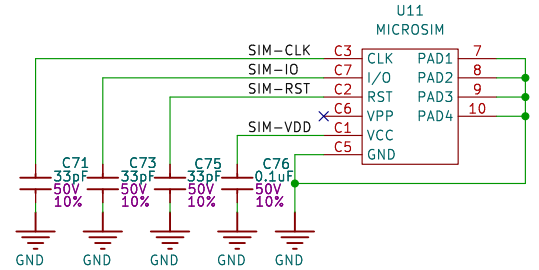
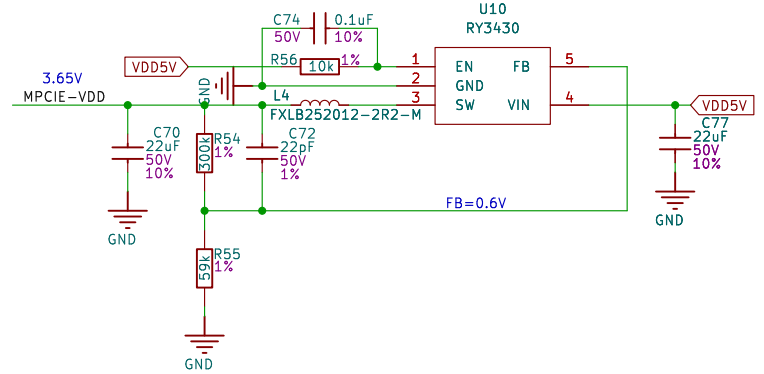
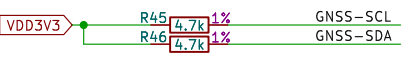
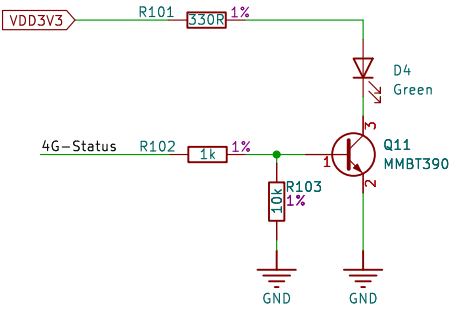

1.设计兼容4G和LoRa网关模块, 只能二选一插入Mini-PCIE 52PIN Socket;
 2.4G模块为Quectel EC20 R2.1;
 3.LoRa网关模块为RAKwireless RAK2287;

Sheet: /Gateway/	
File: MiniPCIE.kicad_sch	
Title:	
Size: A4	Date:
KiCad E.D.A. kicad 7.0.7	Rev:
	Id: 6/14

标准30PIN 单8位LVDS/MIPI管脚定义如下：

- 1:NC
- 2-3:VDD
- 4-7:NC
- 8:LVDS-V0N/MIPI-DSI-D0N
- 9:LVDS-V0P/MIPI-DSI-D0P
- 10:GND
- 11:LVDS-V1N/MIPI-DSI-D1N
- 12:LVDS-V1P/MIPI-DSI-D1P
- 13:GND
- 14:LVDS-V2N/MIPI-DSI-CKN
- 15:LVDS-V2P/MIPI-DSI-CKP
- 16:GND
- 17:LVDS-CKN/MIPI-DSI-D2N
- 18:LVDS-CKP/MIPI-DSI-D2P
- 19:GND
- 20:LVDS-V3N/MIPI-DSI-D3N
- 21:LVDS-V3P/MIPI-DSI-D3P
- 22:GND
- 23-30:NC

30PIN连接器在标准LVDS接口的基础上增加如下信号：

- 1.LCD屏电源控制信号；
- 2.LCD背光PWM调光信号；
- 3.GT911电容触摸屏接口信号：RST/VCC/GND/INT/SDA/SCL；

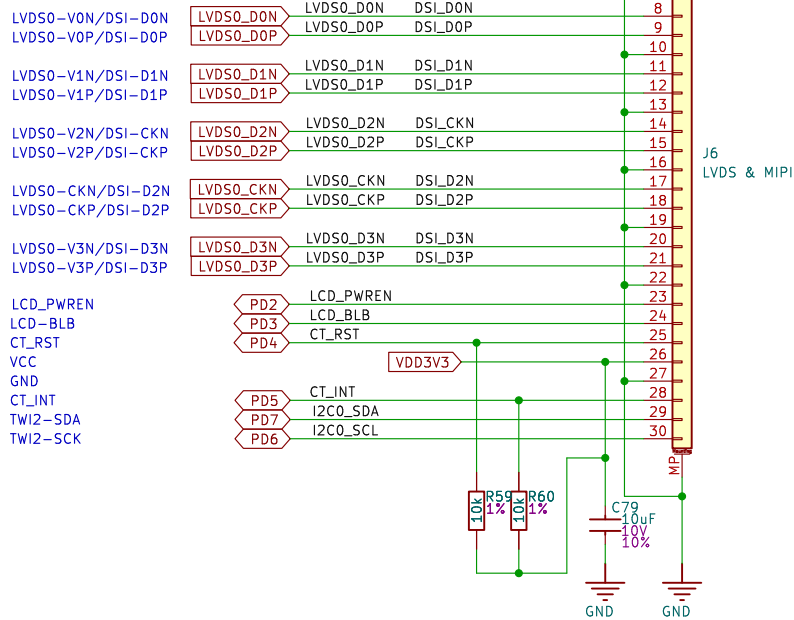

- 1.如果外接RGB屏，需要外部增加LVDS2RGB或者MIPI2RGB信号转接板；
- 2.通用50PIN RGB接口屏管脚定义如下：

- 1-2:Vled+
- 3-4:Vled-
- 5:GND
- 6:VCOM
- 7:DVDD
- 8:MODE
- 9:DE
- 10:VSYNC
- 11:HSYNC
- 12-19:B7-B0
- 20-27:G7-G0
- 28-35:R7-R0
- 36:GND
- 37:PCLK
- 38:GND
- 39:L/R
- 40:U/D
- 41:VGH
- 42:VGL
- 43:AVDD
- 44:RESET
- 45:NC
- 46:VCOM
- 47:DITHB
- 48:GND
- 49-50:NC

RGB屏接口设计说明

MODE:上拉10K至DVDD;

When select DE mode, MODE="1", VS and HS must pull high.
When select SYNC mode, MODE="0", DE must be grounded.

L/R:下拉10K至GND;

U/D:上拉10K至DVDD;

Setting of scan control input		
U/D	L/R	Scanning direction
0	1	Up to down, left to right
1	0	Down to up, right to left
0	0	Up to down, right to left
1	1	Down to up, left to right

RESET:上拉10K至DVDD;

DITHB:下拉10K至GND;

When DITHB="1",Disable internal dithering function,
When DITHB="0",Enable internal dithering function,

When input 18 bits RGB data, the two low bits of R,G and B data must be grounded.

Sheet: /LVDS-MIPI/
File: Display.kicad_sch

Title:

Size: A4

Date:

KiCad E.D.A. kicad 7.0.7

Rev:

Id: 7/14

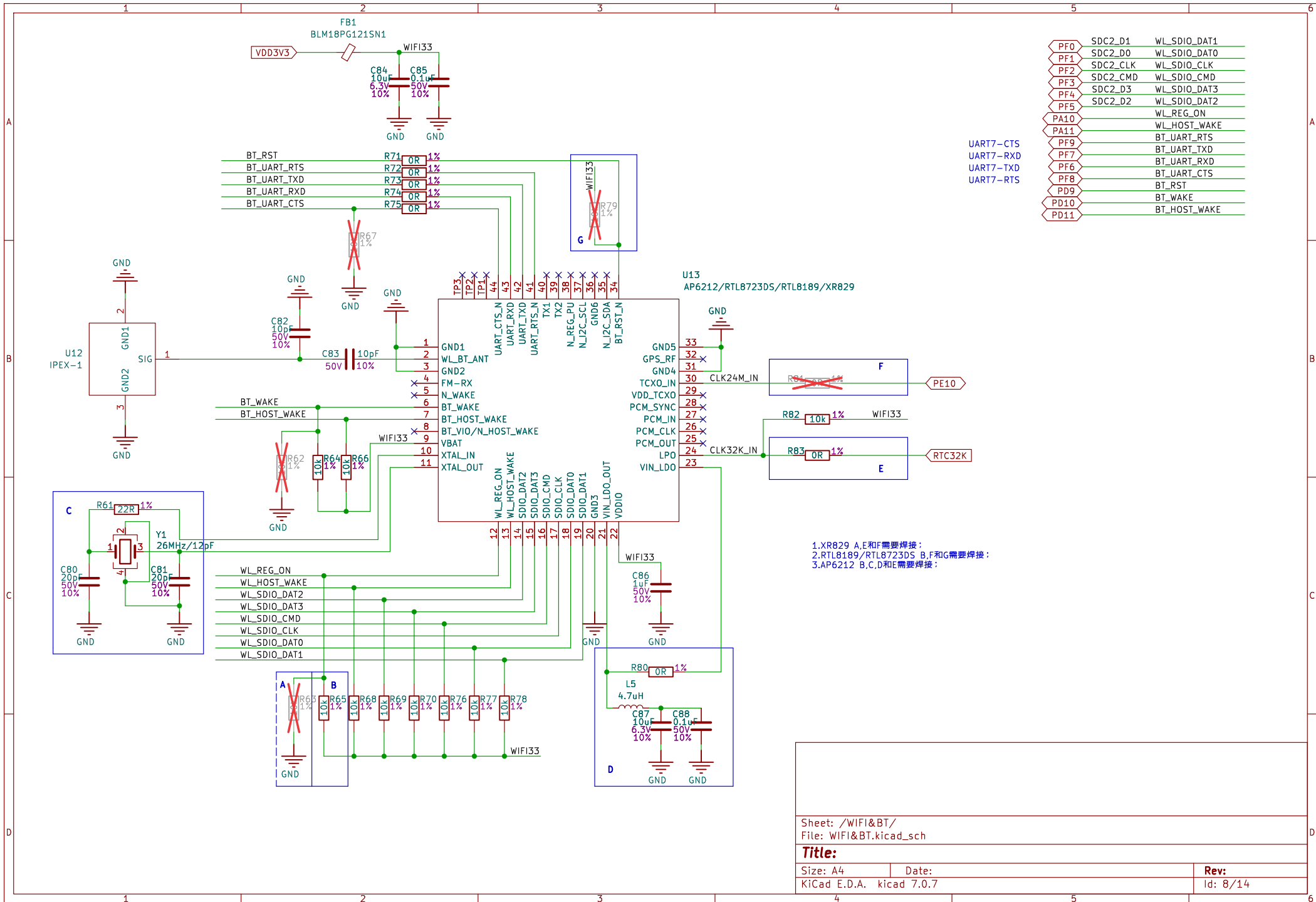

PF0	SDC2_D1	WL_SDIO_DAT1
PF1	SDC2_D0	WL_SDIO_DAT0
PF2	SDC2_CLK	WL_SDIO_CLK
PF3	SDC2_CMD	WL_SDIO_CMD
PF4	SDC2_D3	WL_SDIO_DAT3
PF5	SDC2_D2	WL_SDIO_DAT2
PA10		WL_REG_ON
PA11		WL_HOST_WAKE
PF9		BT_UART_RTS
PF7		BT_UART_TXD
PF6		BT_UART_RXD
PF8		BT_UART_CTS
PD9		BT_RST
PD10		BT_WAKE
PD11		BT_HOST_WAKE

UART7-CTS
 UART7-RXD
 UART7-TXD
 UART7-RTS

- 1.XR829 A,E和F需要焊接;
- 2.RTL8189/RTL8723DS B,F和G需要焊接;
- 3.AP6212 B,C,D和E需要焊接;

Sheet: /WiFi&BT/	
File: WiFi&BT.kicad_sch	
Title:	
Size: A4	Date:
KiCad E.D.A. kicad 7.0.7	Rev:
	Id: 8/14

PE8	GMACO_MDC	RGMI1-MDC
PE9	GMACO_MDIO	RGMI1-MDIO
PE2	GMACO_RXCTL	RGMI1-RXCTL
PE13	GMACO_RXCLK	RGMI1-RXC
PE1	GMACO_RXD0	RGMI1-RXD0
PE0	GMACO_RXD1	RGMI1-RXD1
PE12	GMACO_RXD2	RGMI1-RXD2
PE11	GMACO_RXD3	RGMI1-RXD3
PE7	GMACO_TXCTL	RGMI1-TXCTL
PE6	GMACO_TXCLK	RGMI1-TXC
PE5	GMACO_TXD0	RGMI1-TXD0
PE4	GMACO_TXD1	RGMI1-TXD1
PE15	GMACO_TXD2	RGMI1-TXD2
PE14	GMACO_TXD3	RGMI1-TXD3
PE16		PHYINTB

PE3 GMACO_CLKIN 125MCLKOUT

AVDD33	1	AVDD33
MDIOP	2	TRXOP
MDION	3	TRXON
AVDDL	4	AVDDL
MD1P	5	TRX1P
MD1N	6	TRX1N
MDI2P	7	TRX2P
MDI2N	8	TRX2N
AVDDL	9	AVDDL
MDI3P	10	TRX3P
MDI3N	11	TRX3N
AVDD33	12	AVDD33

UTP <=> RGMII
 RXC delay enable
 PHYAD2
 PHYAD1
 PHYAD0
 PHYADDR=0x000
 RGMII 3.3V

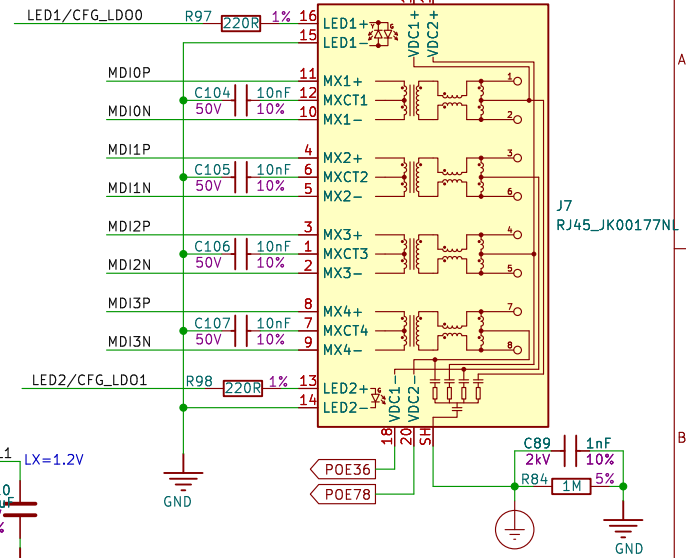
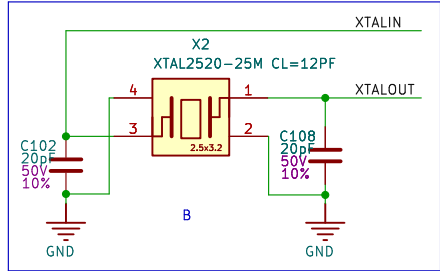
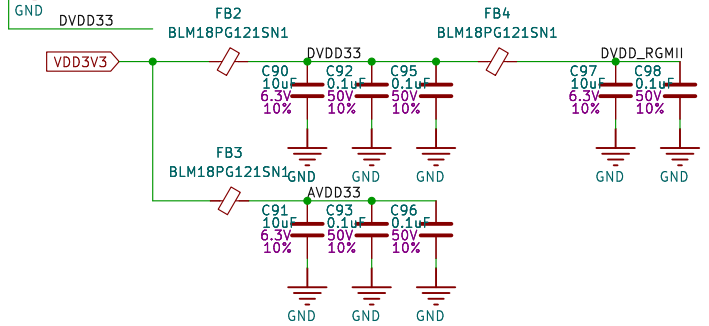
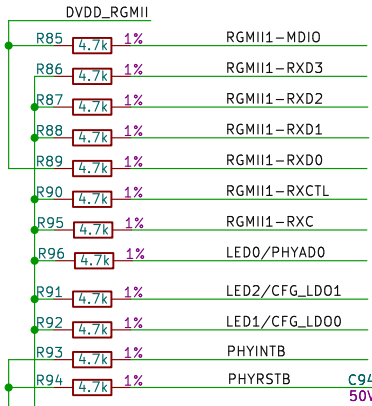
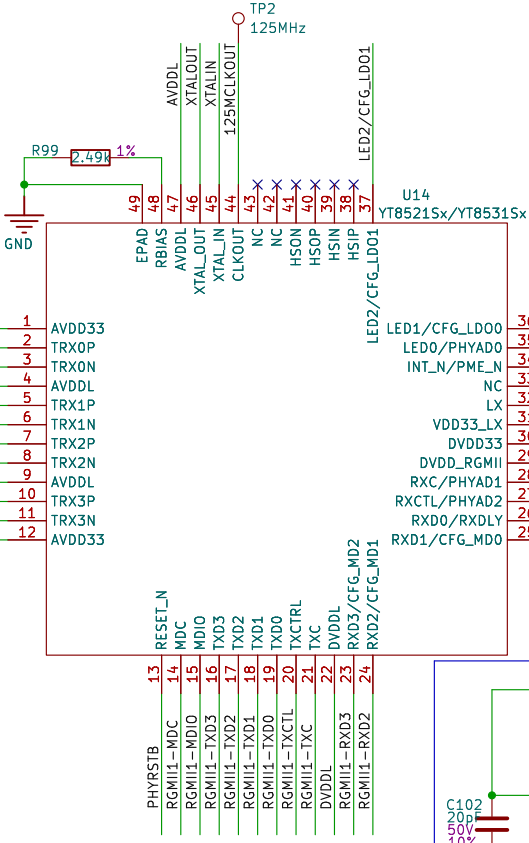

RGMII Power Source	CFG-LD0[1..0]
External 3.3V(Default)	00
External 2.5V	01
External 1.8V	10
Not Available	11

Operation Mode	RXD[3..1]
UTP <=> RGMII	000
FIBER <=> RGMII	001
UTP/FIBER <=> RGMII	010
UTP <=> SGMII	011
SGMII (PHY) <=> RGMII	100
SGMII (MAC) <=> RGMII	101
UTP <=> FIBER (AUTO)	110
UTP <=> FIBER (FORCE)	111

- 除了PHYIO配置为3.3V需要焊接A区域磁珠外,其他PHYIO电压均是PHY内部电源调节器产生,因此无需焊接A区域磁珠.
- LED1:When 100Mbps links up,LED1 is on;when Data is transmitted ,LED1 will blink.
- LED2:When 1000Mbps links up,LED2 is on;when Data is transmitted ,LED2 will blink.

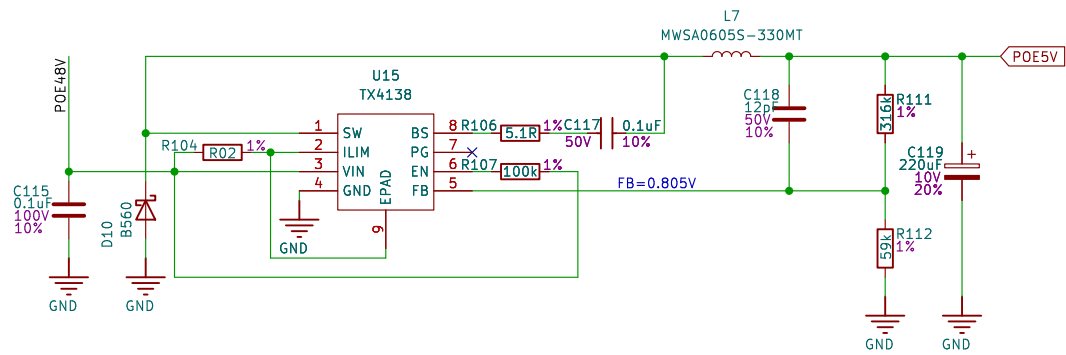
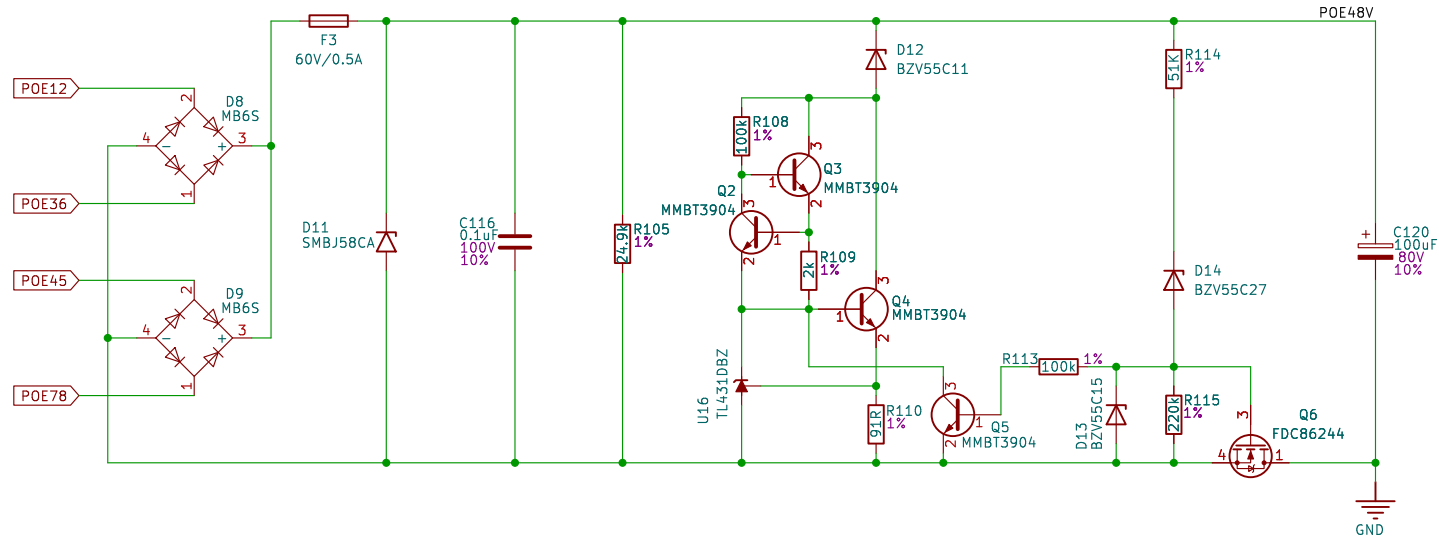

Sheet: /POE/	
File: TX4138.kicad_sch	
Title:	
Size: A4	Date:
KiCad E.D.A. kicad 7.0.7	Rev: Id: 10/14

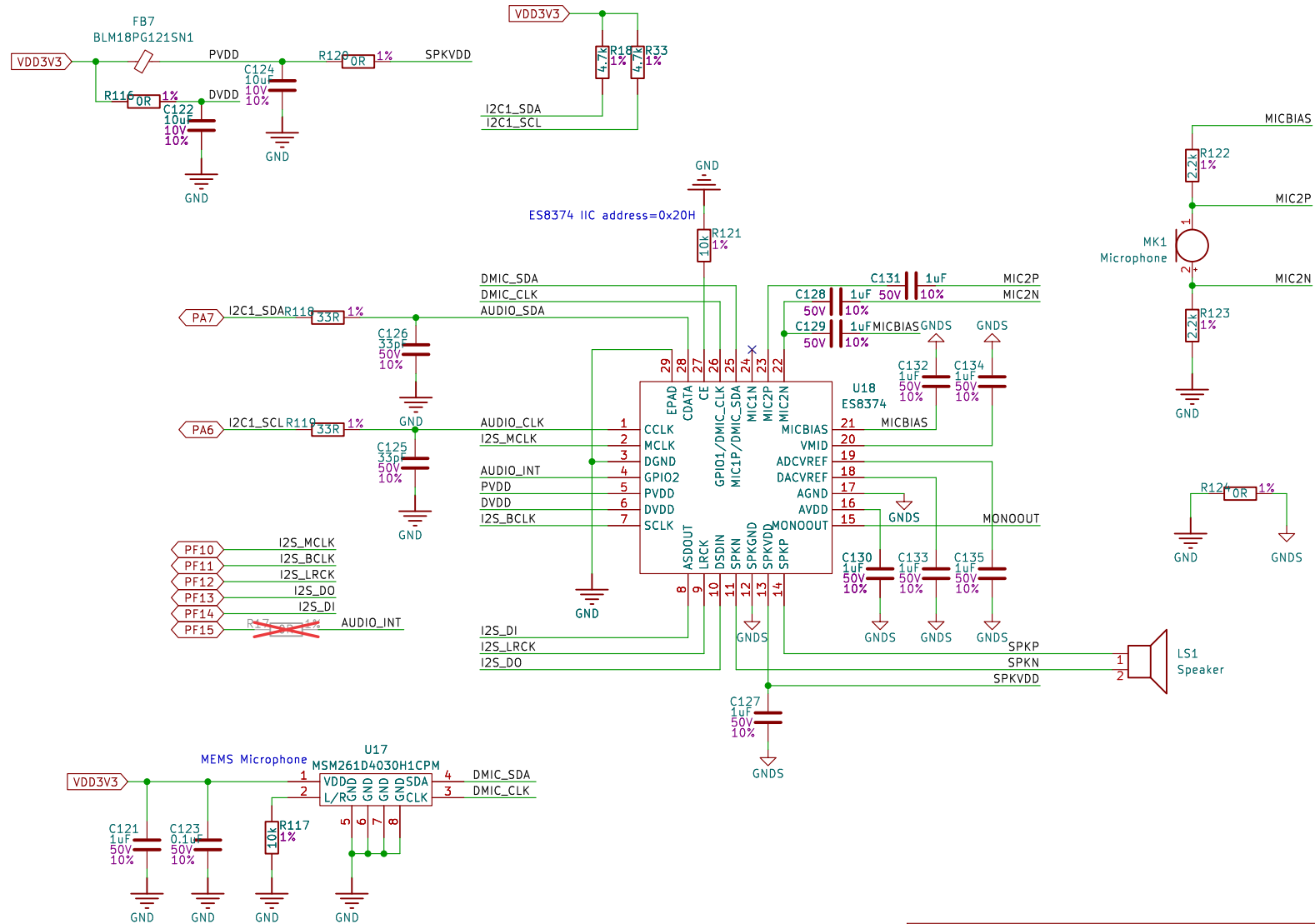

Sheet: /Audio/
File: ES8374.kicad_sch

Title:

Size: A4
KiCad E.D.A. kicad 7.0.7

Date:

Rev:

Id: 11/14

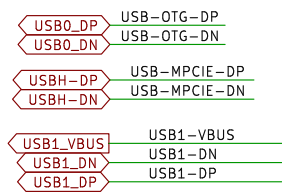
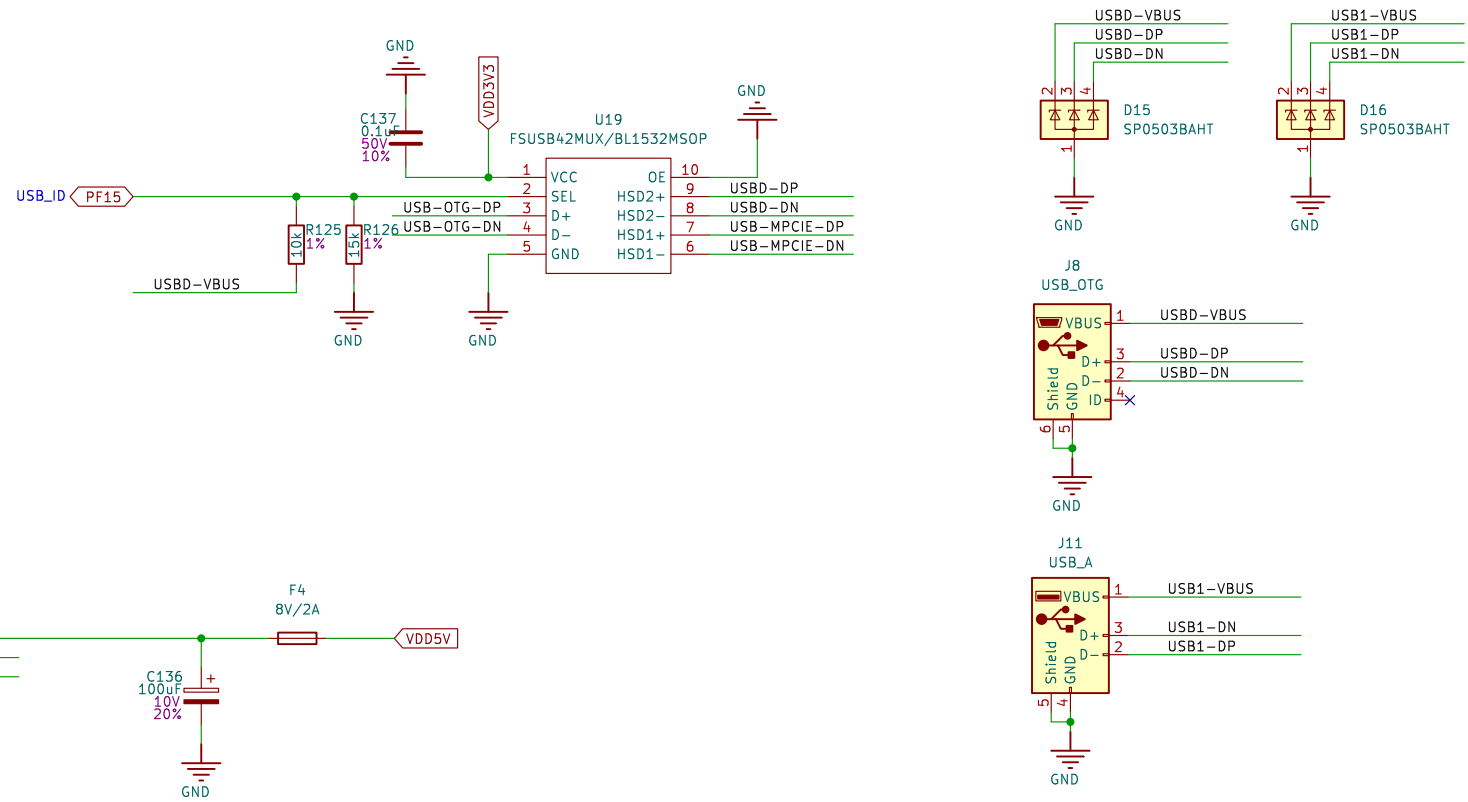

Sheet: /USB/		Date:	
File: OTG.kicad_sch		Rev:	
Size: A4	KiCad E.D.A. kicad 7.0.7	Id: 12/14	

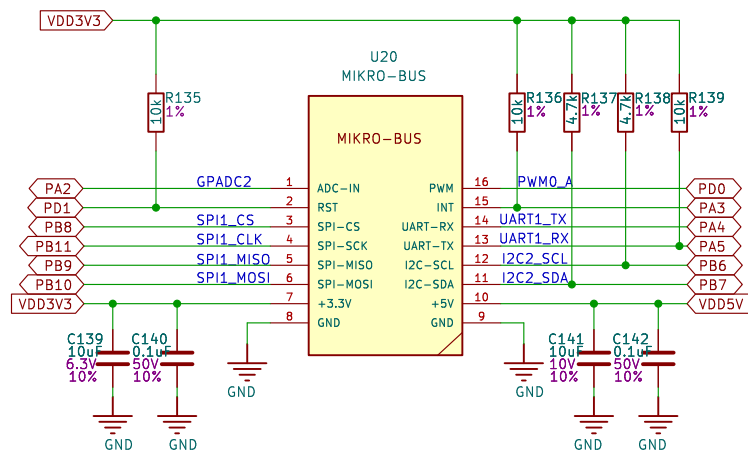
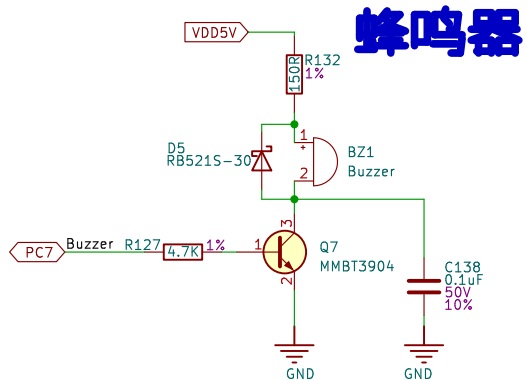

系统状态

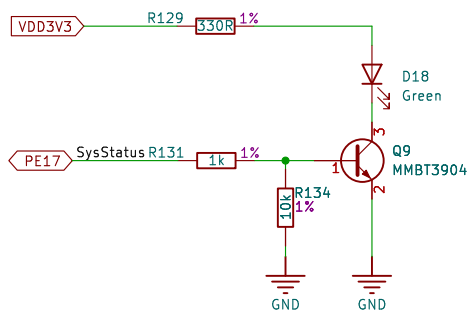

电源指示

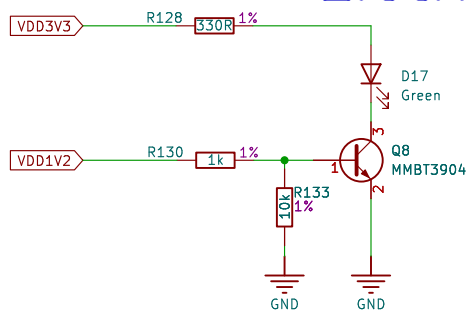

Sheet: /MISCs/
File: MISCs.kicad_sch

Title:

Size: A4
KiCad E.D.A. kicad 7.0.7

Date:

Rev:

Id: 13/14

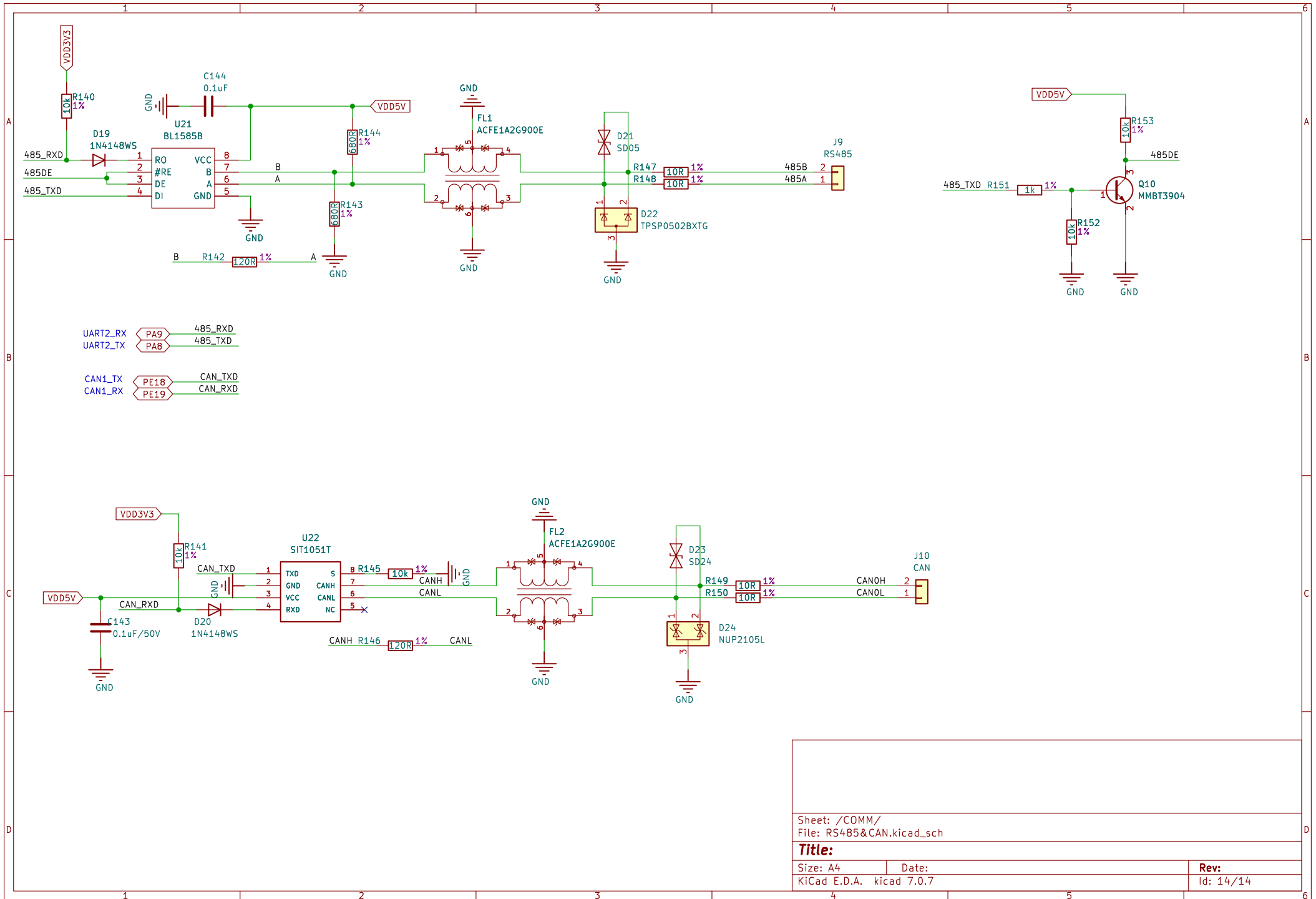

Sheet: /COMM/
 File: RS485&CAN.kicad_sch

Title:

Size: A4
 KiCad E.D.A. kicad 7.0.7

Date:

Rev:
 Id: 14/14